

# Dover Waterfront District Draft Design Guidelines



*Presented by:*

**The Cecil Group**

**September 29, 2008**



# Agenda

- Design Review Process
- General Design Principles and Standards
- Private Sector Development Design Standards
- Waterfront Park Design Standards
- Design Standards for Public Ways

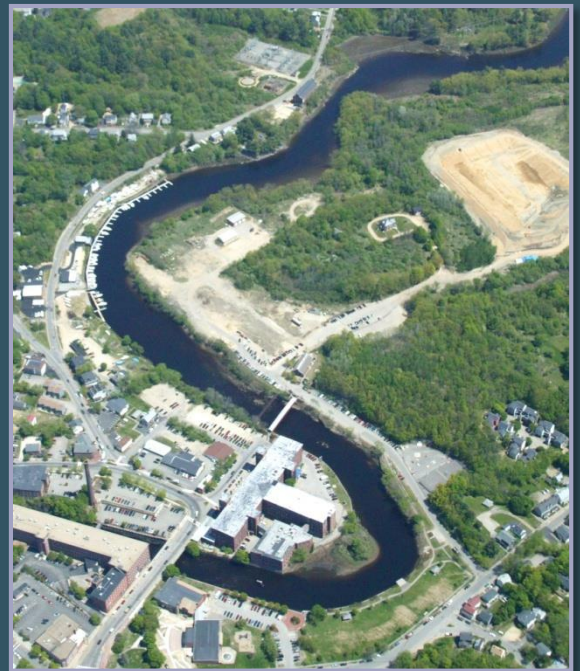

# Introduction and Scope of the Design Guidelines

- Purpose of the Design Guidelines - standards for the visual qualities of the design and subsequent development that will compose the Dover Waterfront along the Cochecho River...design characteristics directly associated with established public purposes and interests

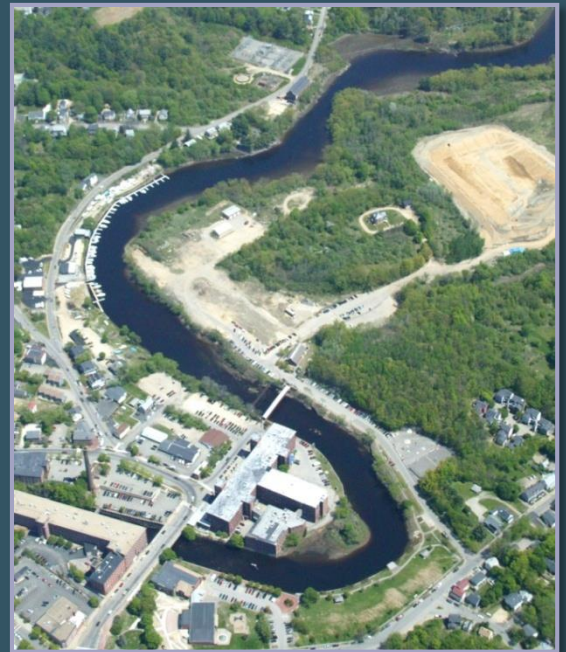

# Design Review Process

- Compliance
- Background
- Process
- Compliance Alternatives

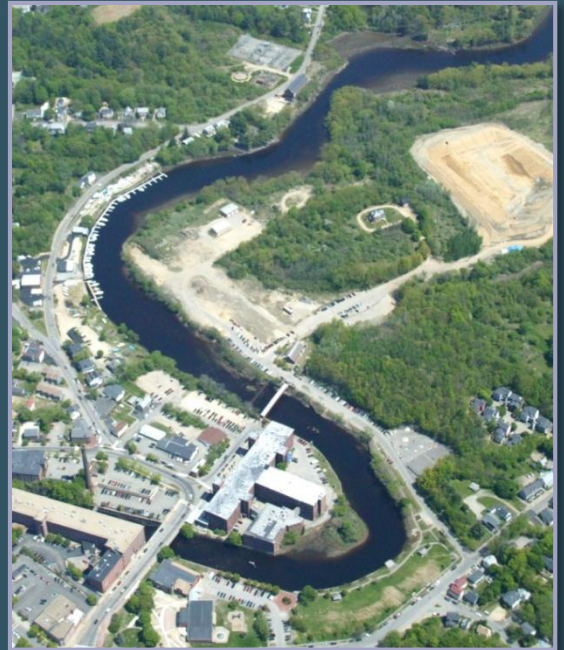





# General Design Principles and Standards

## Shared Design Principles

- Urban Character
- Relationship with the Downtown
- Grading and Conformance with Topography
- Street and Walkway Connections
- Varied Landscape Character: Combination of Formal and Informal

# General Principles

## Design Standards

### Architectural Character

- Valued existing and historic buildings should be employed as precedents...and inspirations for new interpretations



# General Principles Design Standards Architectural Character





# General Principles Design Standards Architectural Character





# General Principles Design Standards Contours and Site Planning

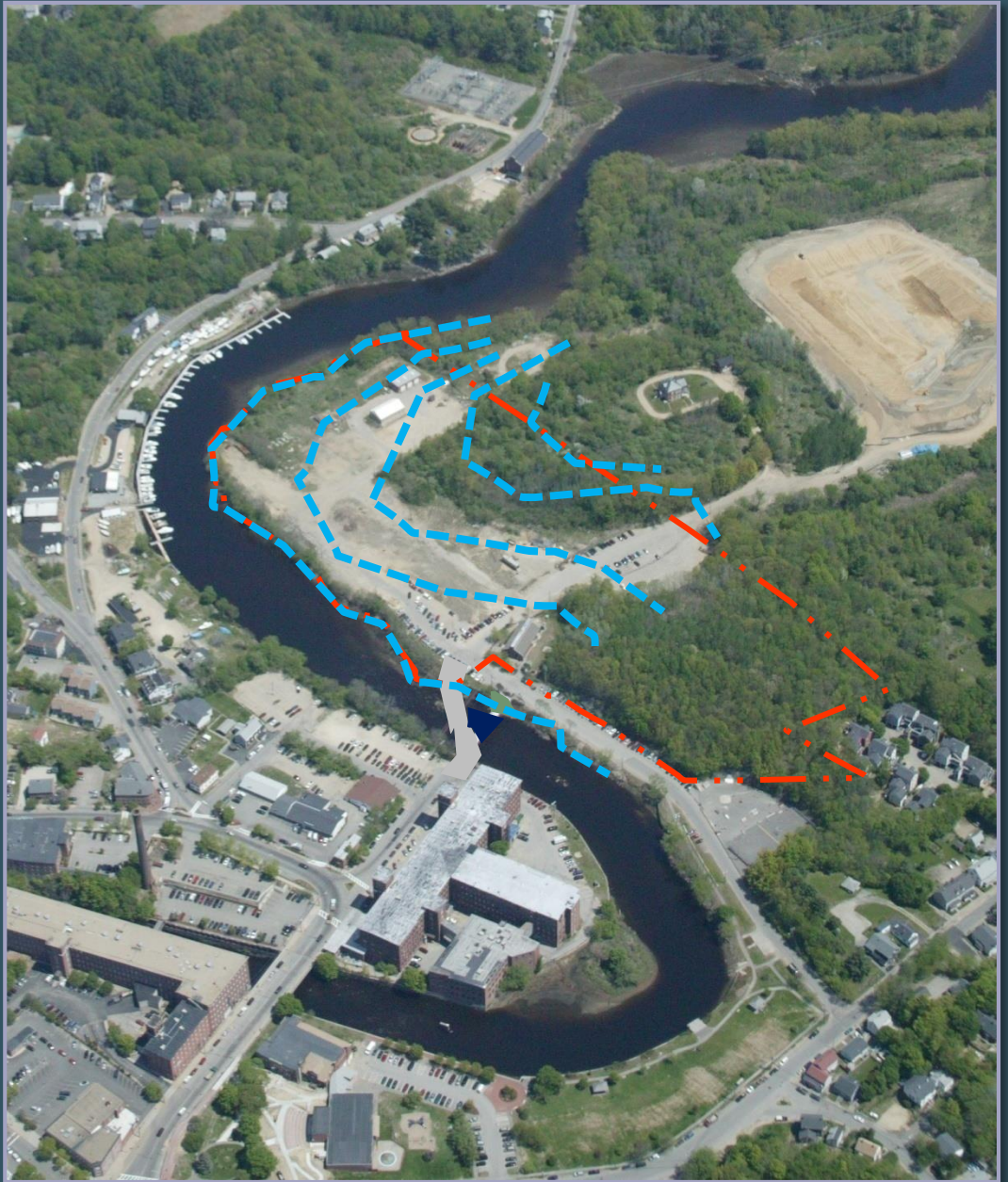





# General Design Principles

## Project Area





# General Design Principles

## Open Space Segments

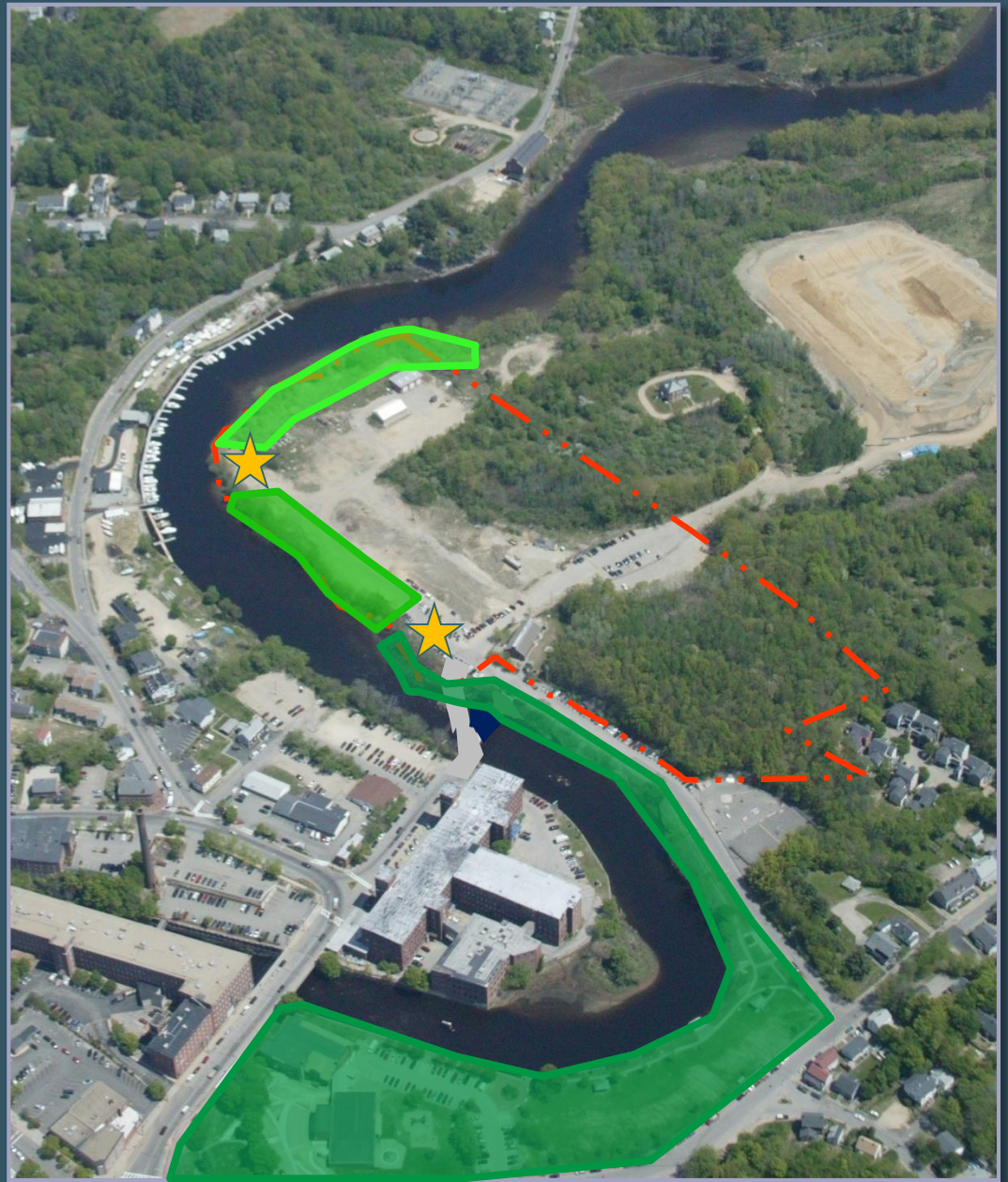





# General Design Principles and Standards

## Shared Design Standards

- Riverfront Access and Circulation
- Landscaping
- Lighting
- Signage





# General Design Principles

## Pedestrian Network

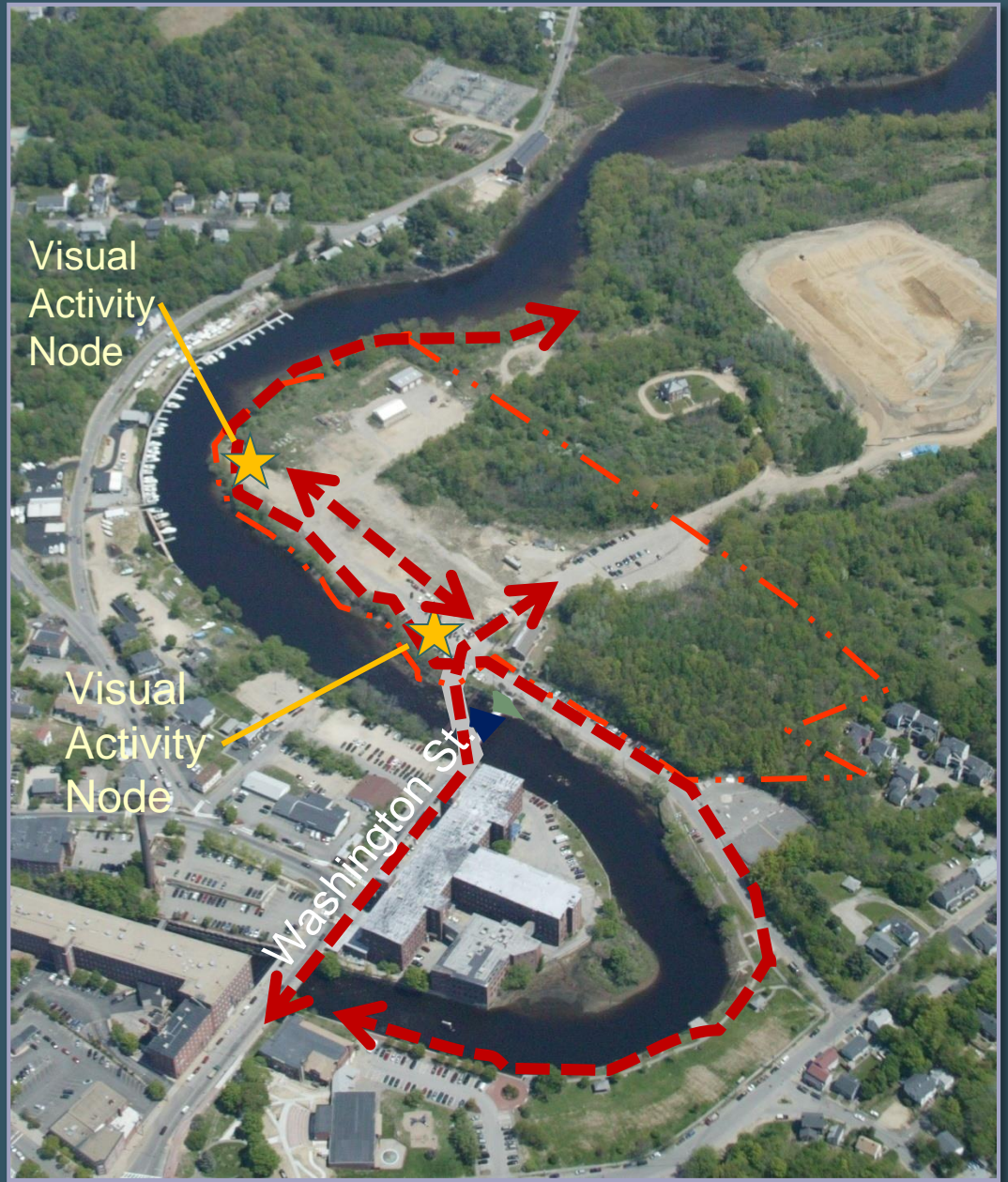

# General Design Principles

FIGURE 1: Plan Diagram: Riverfront Building, Street and Open Space Relationships

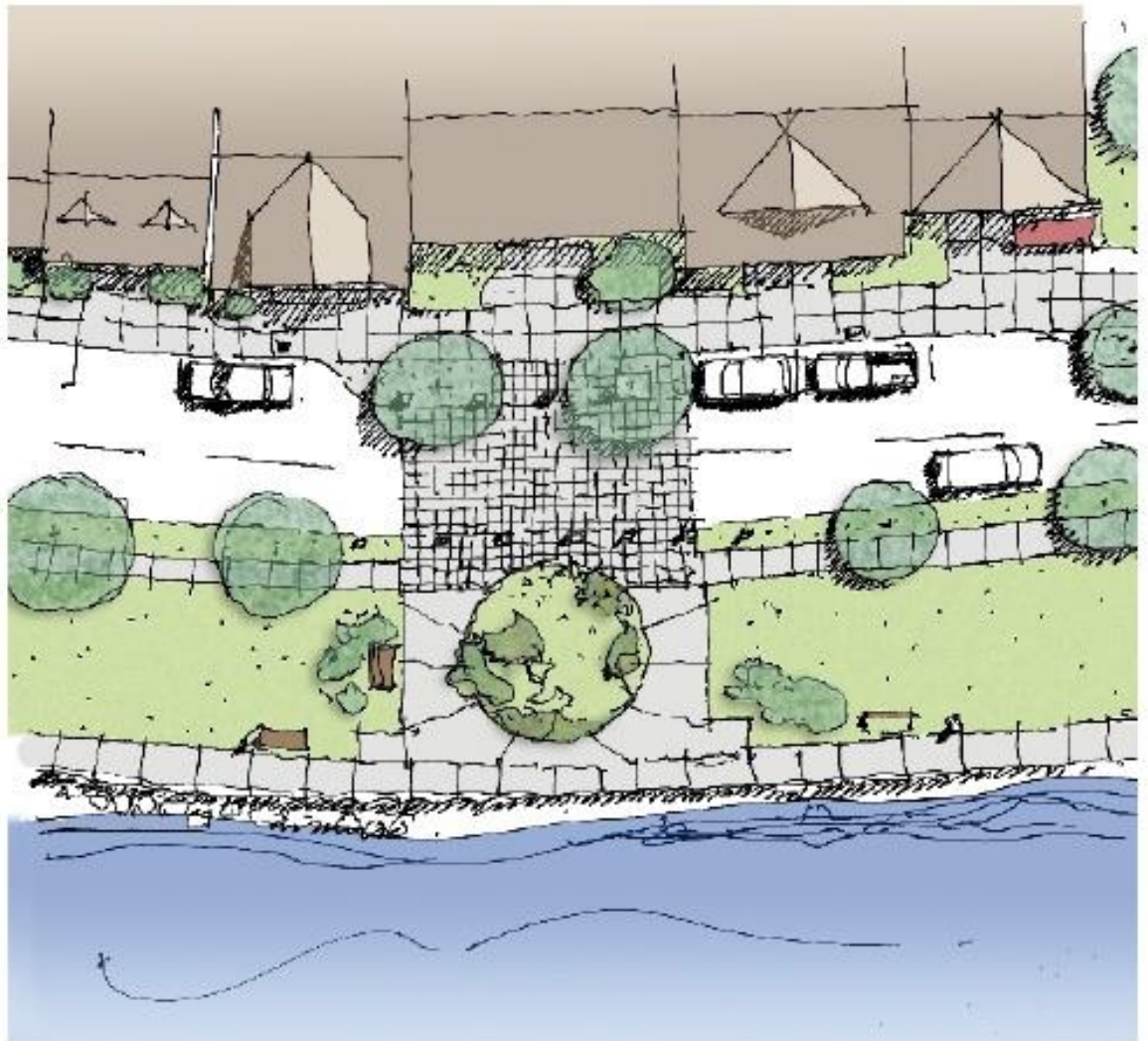

# General Design Principles

FIGURE 2: Section Diagram: Riverfront Building, Street and Open Space Relationships

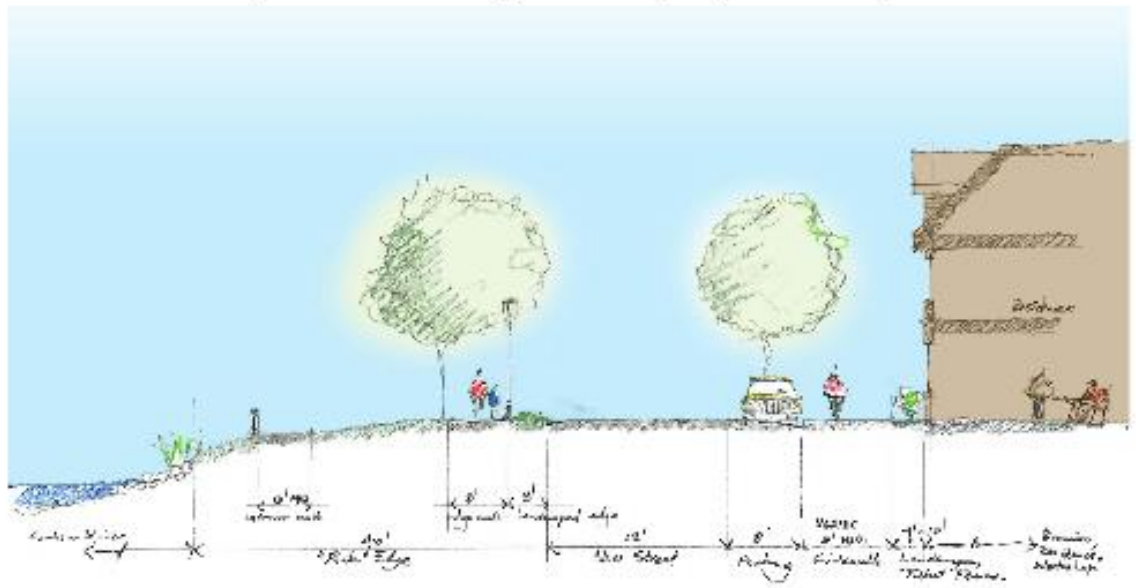



# General Design Principles

FIGURE 3: Section Diagram, Alternative Configuration: Riverfront Building, Street and Open Space Relationships

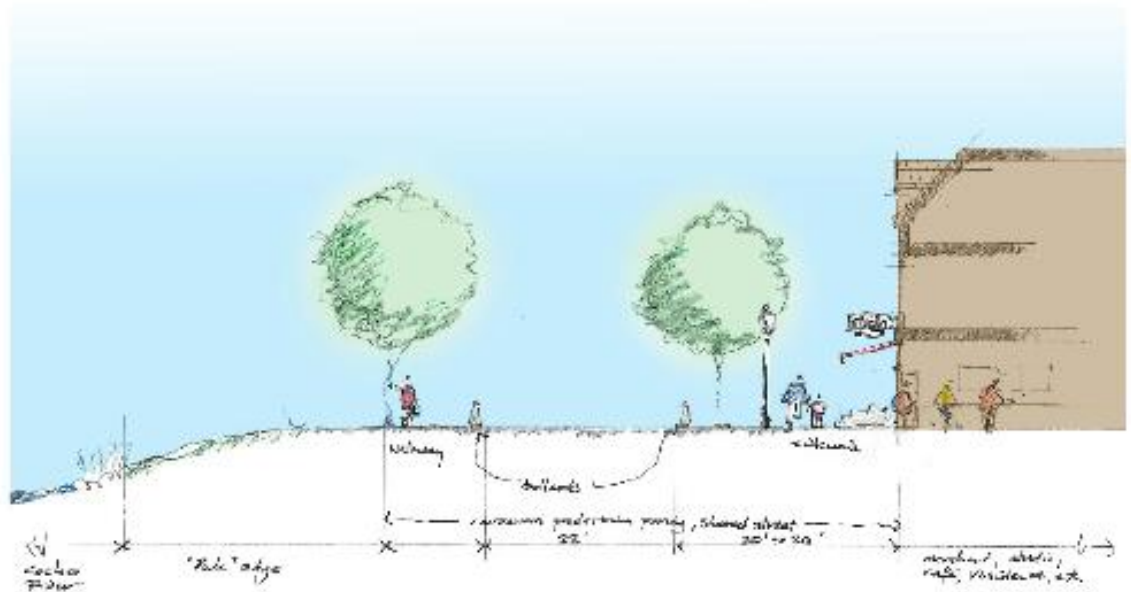



# General Design Principles

FIGURE 4: Section Diagram: Pedestrian Path and Building Relationships

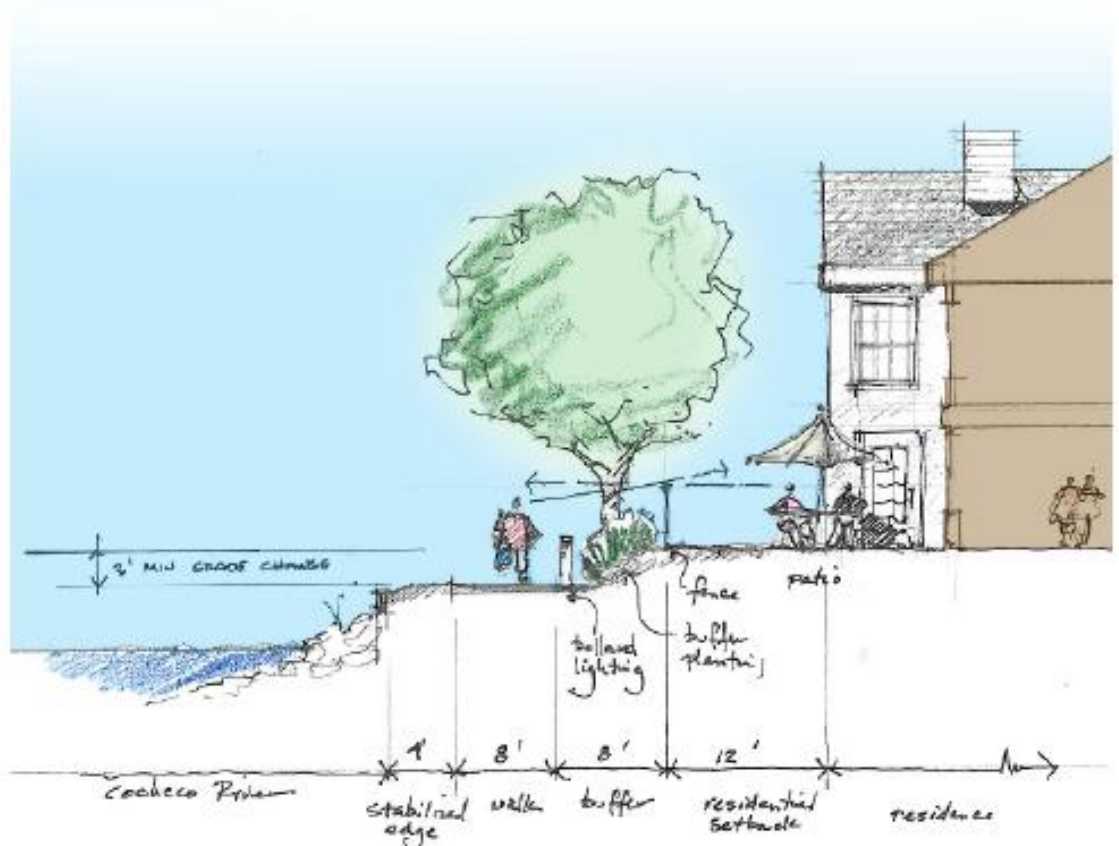

# General Design Principles and Standards

## Shared Design Standards

- Riverfront Access and Circulation
- Landscaping
- Lighting
- Signage

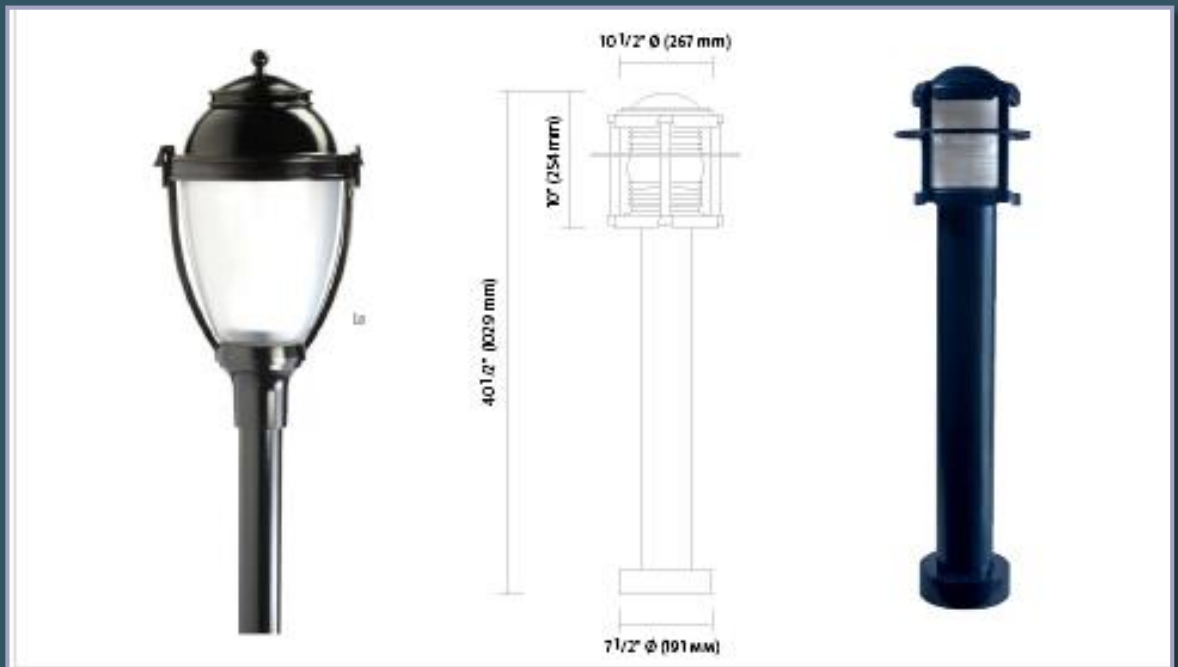



# Private Sector Development Design Standards

## Architecture

- Character
- Siting of Buildings
- Massing and Articulation
- Roofs
- Façade Elements
- Fenestration
- Awnings and Canopies
- Materials
- Colors

# Private Sector Development Design Standards Architectural Character







# Private Sector Development Design Standards

## Architecture

- Character
- Siting of Buildings
- Massing and Articulation
- Roofs
- Façade Elements
- Fenestration
- Awnings and Canopies
- Materials
- Colors



# Private Sector Development Design Standards

## Landscaping and Open Space Requirements

- Common Open Spaces
- Pedestrian Access/Pedestrian Ways
- Site Furniture
- Buffers
- Parking Areas

## Exterior and Site Lighting

## Streets, Drives and Loading Areas

# Riverfront Public Open Space Design Standards

## Character



# Riverfront Public Open Space Design Standards

## Public Open Space Elements

- Open Spaces
- Land Form and Structures
- Pedestrian Site Circulation
- Water Access
- Gateways
- Paving Materials
- Riverside Boardwalk or Sidewalk





# Riverfront Public Open Space Design Standards

## Public Open Space Elements

- Pedestrian Character
- Lighting
- Plantings
- Site Furniture
- Signage
- Parking
- Public Art
- Public Restrooms

## Operations and Maintenance



# Design Standards for Public Ways

Streets

Sidewalks

Streetscape and Landscaping

On-street Parking

Signage

Operations and Maintenance

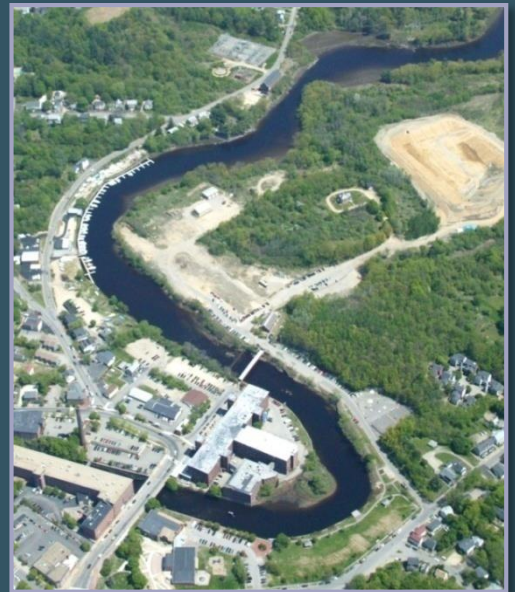

# Dover Waterfront District Draft Design Guidelines



*Presented by:*

**The Cecil Group**

**September 29, 2008**

