

ANN M. LEGERE, CPPB  
Deputy Finance Director  
[a.legere@dover.nh.gov](mailto:a.legere@dover.nh.gov)

LIBBY M. SIMMONS  
Purchasing Agent  
[l.simmons@dover.nh.gov](mailto:l.simmons@dover.nh.gov)

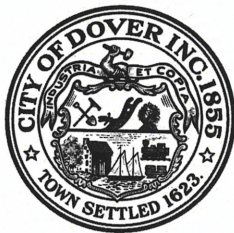

288 Central Avenue  
Dover, New Hampshire 03820-4169

(603) 516-6030  
Fax: (603) 516-6097  
[www.dover.nh.gov](http://www.dover.nh.gov)

***City of Dover, New Hampshire***  
OFFICE OF THE FINANCE DIRECTOR

March 4, 2020

**REQUEST FOR PROPOSAL B20048**  
**Wayfinding and Information System**

You are cordially invited to submit a Proposal **Wayfinding and Information System** in accordance with the attached specifications, terms and conditions. Prospective respondents are advised to read this information over carefully prior to submitting a proposal.

**TWO (2) copies of the Proposal must be submitted in a sealed envelope, plainly marked:**

**RFP #B20048- Wayfinding and Information System**  
**Purchasing/Finance Office**  
**City of Dover**  
**288 Central Ave 2<sup>nd</sup>. Floor**  
**Dover NH 03820**

All proposals/bids must be received by **March 24, 2020 at 3:00 p.m. EST**

LMS:kjn  
Attachments

**IMPORTANT:**

In order to be notified by email for projects associated with your service, visit our web page, <http://www.dover.nh.gov/government/city-operations/finance/bids> proceed to BECOME A VENDOR and add your company to our vendor database (if you have not already done so).

**Supplies Code- 07 metals, signs and related items**



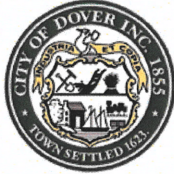

**CITY OF DOVER**

## REQUEST FOR BID, PROPOSAL, QUOTATION

Request Type Proposal Number: **B20048**  
Title **Wayfinding and Information System**  
Date March 4, 2020

### I. INTRODUCTION

The City of Dover is requesting pricing and availability from qualified vendors to perform City exterior wayfinding services. General information and specifications are as follows.

### II. GENERAL REQUIREMENTS

The City of Dover reserves the right to waive any formality, informality, information and/or errors in the proposals submitted and the right to reject any or all proposals at its discretion and to accept the proposal which will be in the best interest of the City; or to purchase on the open market if it is considered in the best interest of the City to do so.

Any questions or inquiries must be submitted in writing, and, in order to be considered, must be received by the Purchasing Agent ([l.simmons@dover.nh.gov](mailto:l.simmons@dover.nh.gov)) no later than seven (7) calendar days before the Request for Proposals due date and time. Any changes to the Request for Proposals will be provided to all Proposers of record.

No Late, Emailed or Faxed proposals will be accepted.

### III PROJECT REQUIREMENTS

See Attachment C – Project Manual - **No** Federal Provisions or **Liquidated Damages apply to this contract.**

### IV INFORMATION AVAILABLE

Attachment A Terms and Conditions  
Attachment B Sample Agreement and Vendor Application  
Attachment C Project Specifications, maps, pricing sheet and/or other information

Any exceptions to the terms and conditions of any of the attachments shall be submitted with the proposal in order to be considered.

### V TIMELINE

The project shall be completed by ~~June 13, 2020.~~ **July 15, 2020, per Addendum 1**

### VI SUBMITTAL REQUIREMENTS (any missing items may result in rejection of the proposal)

#### Costs

Submit a cost proposal on the Attachment C- City Sign System – Project Pricing Sheet.



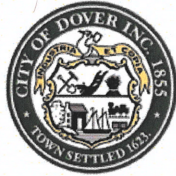

**CITY OF DOVER**

## REQUEST FOR BID, PROPOSAL, QUOTATION

Request Type Proposal

Number: B20048

Title **Wayfinding and Information System**

Date March 4, 2020

### Statement of Project Requirements

State in succinct terms the vendors understanding of what is required by this Request for Proposal. The vendor shall demonstrate their knowledge of the project by documenting design and construction issues associated with this Project.

### Scope of Services

Describe in narrative form the vendors approach and technical plan for accomplishing the work listed herein. Submit a schedule for completing the scope of work outlining the anticipated time frames and durations for the various services specified in the project approach.

### Firm

Information on the firm shall be provided as requested in **Attachment C-Project Specifications**. Such information shall elaborate on the firm's size, areas of specialization, and list current projects underway. Provide similar information on all subcontractors that will be utilized.

### Team

Include a Project Team Chart of all individuals who will be assigned to work on this project. Also, list any proposed sub-consultants and their intended scope of work.

### Commitments

Provide a discussion of how the vendor will assure adequate and timely completion of this project. Submit a description of the vendor's overall capability, resources and assurance that it can meet its commitment to successfully complete this project within the specified time frame.

### References

Recent names and phone number information must be provided for at least three (3) other customers for whom these types of services have been successfully provided.

## VII SELECTION

Consultant selection will include, but are not limited to the following:

- Firm's qualifications
- Experience of the firm and individuals on similar projects
- Qualifications of subcontractors/subconsultants
- Understanding of the Project Scope
- Approach for completing the Work
- References from like work experiences
- Proposal Costs
- Commitment to Project timeline
- Any other criteria determined appropriate by the City



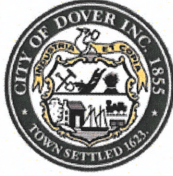

**CITY OF DOVER**

# REQUEST FOR BID, PROPOSAL, QUOTATION

Request Type **Proposal** Number: **B20048**  
 Title **Wayfinding and Information System**  
 Date **March 4, 2020**

**CONTACT INFORMATION: Proposer must complete the following:** By signing this proposal form you are attesting to your awareness and agreement with proposal terms and conditions. I certify that I am authorized to sign this form for the Proposer.

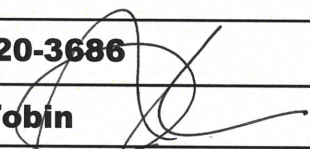
Official Entity Name	<b>Hilton Displays, LLC</b>	FOB Information:	Dover NH
Address:	<b>125 Hillside Drive</b>		
City, State, Zip	<b>Greenville, SC 29607</b>		
Email address:	<b>williamclark@hiltondisplays.com</b>	State of Incorporation	<b>South Carolina</b>
Date:	<b>3/30/2020</b>	SSN or EIN:	<b>57-0726711</b>
Telephone #:	<b>864-520-3686</b>	Fax #:	<b>864-242-2204</b>
Signature:	<b>Tom Tobin</b> 	Title:	<b>President</b>

*We, the undersigned have declined to submit a proposal for:*

- Insufficient time to respond*
- We do not offer this product or service*
- Our schedule would not permit us to perform*
- Unable to meet specifications*
- Unable to meet bond requirements*
- Unable to meet insurance requirements*
- Specifications too stringent (explain below)*
- Other*

*NO BID*



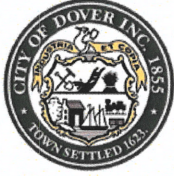

**CITY OF DOVER**

## REQUEST FOR BID, PROPOSAL, QUOTATION

Request Type Proposal Number: **B20048**  
Title **Wayfinding and Information System**  
Date March 4, 2020

Cut and affix this label to your sealed bid envelope to identify it as a "SEALED BID" Be sure to include the name of the company submitting the bid where requested.

<b>SEALED BID * DO NOT OPEN</b>	
Sealed bid #:	<b>B20048</b>
Bid Title:	<b>Wayfinding and Information System</b>
Due Date/Time:	<b>March 24, 2020 at 3:00 p.m. EST</b>
Submitted by:	<b>Hilton Displays, LLC</b>
<b>DELIVER TO:</b>	
<p style="text-align: center;"><i>City of Dover Purchasing &amp; Finance Office City of Dover NH City Hall 288 Central Ave 2<sup>nd</sup> Fl Dover NH 03820</i></p>	

From time to time, addenda may be issued to this bid. Any such addenda will be posted on the same website from which you obtained this bid.

<http://www.dover.nh.gov/government/city-operations/finance/bids/>

Before submitting your bid you should check our website to download any addenda that may have been issued. Be sure to mark your sealed bid envelope that you have received all addenda.



City Wayfinding System Dover, NH  
 Fabrication+Installation Pricing Matrix 24 Februar 2020  
 City Sign System – Project Pricing

Qty	Type	Description	Unit fabrication	Unit installation	Unit Total	Combined Fabrication	Combined Installation	Combined Total
1	G1.0	Primary Gateway > arc grfd/freestanding	\$ 20,039.00	\$ 4,800.00	\$ 24,839.00	\$ 20,039.00	\$ 4,800.00	\$ 24,839.00
6	G2.0	Secondary Gateway > freestanding	\$ 3,153.00	\$ 3,360.00	\$ 6,513.00	\$ 18,918.00	\$ 20,160.00	\$ 39,078.00
		add/alt. option: breakaway base	\$ 793.00	NA	\$ 793.00	\$ 4,758.00	NA	\$ 4,758.00
8	D1.0	Primary Directional > freestanding	\$ 3,123.00	\$ 3,360.00	\$ 6,483.00	\$ 24,984.00	\$ 26,580.00	\$ 51,864.00
		add/alt. option: breakaway base	\$ 793.00	NA	\$ 793.00	\$ 6,344.00	NA	\$ 6,344.00
1	D1.4	Primary Directional > panel only; on existing mast arm post	\$ 1,356.00	\$ 400.00	\$ 1,756.00	\$ 1,356.00	\$ 400.00	\$ 1,756.00
10	D2.0	Secondary Directional > freestanding	\$ 2,995.00	\$ 3,000.00	\$ 5,995.00	\$ 29,950.00	\$ 30,000.00	\$ 59,950.00
11	D3.0	Tertiary Directional > freestanding	\$ 2,216.00	\$ 3,000.00	\$ 5,216.00	\$ 24,376.00	\$ 33,000.00	\$ 57,376.00
1	D3.P	Tertiary Directional > panel only; mounted on existing post TBD	\$ 923.00	\$ 400.00	\$ 1,323.00	\$ 923.00	\$ 400.00	\$ 1,323.00
4	D4	Parking Directional > panel only	\$ 305.00	\$ 240.00	\$ 545.00	\$ 1,220.00	\$ 960.00	\$ 2,180.00
4	D5	Offsite Directional > panel only	\$ 359.00	\$ 275.00	\$ 634.00	\$ 1,436.00	\$ 1,100.00	\$ 2,536.00
4	D6.0	Pedestrian Directional > freestanding	\$ 2,479.00	\$ 1,440.00	\$ 3,919.00	\$ 9,916.00	\$ 5,760.00	\$ 15,676.00
3	V1.0	Visitor Information Table: 1); porcelain enamel graphic panels 2); high-pressure laminate graphic panels	\$ 9,139.00	\$ 2,220.00	\$ 11,359.00	\$ 27,417.00	\$ 6,660.00	\$ 34,077.00
6	V2.1	Visitor Information Post > single-sided: 1); porcelain enamel panels 2); high-pressure laminate	\$ 6,897.00	\$ 1,440.00	\$ 8,337.00	\$ 41,382.00	\$ 8,640.00	\$ 50,022.00
1	V2.2	Visitor Information Post > double-sided: 1); porcelain enamel panels 2); high-pressure laminate	\$ 4,292.00	\$ 1,440.00	\$ 5,732.00	\$ 4,292.00	\$ 1,440.00	\$ 5,732.00
3	A2.0	Secondary Park ID > freestanding/single-sided	\$ 3,462.00	\$ 1,440.00	\$ 4,902.00	\$ 3,462.00	\$ 1,440.00	\$ 4,902.00
		Project Expenses: general conditions, shop drawings, travel, etc.	\$ 1,905.00	\$ 1,800.00	\$ 3,705.00	\$ 5,715.00	\$ 5,400.00	\$ 11,115.00
		Related Costs: estimated/plus % projected						\$ 15,075.00
		Project Total:						\$ 383,701.00

NOTE 1: Project Total is inclusive of the additional costs for breakaway options as noted and represents only the porcelain enamel options for the "V" series signs

NOTE 2: A payment and performance bond cost of 1.5% will be charged to the city but is not included in the total above

NOTE 3: Actual permit costs are not included and will be passed through at cost as an additional charge

\*\*\* = Installation costs are the same for this option and so the installation numbers were excluded in order to avoid doubling these costs in the overall Total





Underground Obstruction Statement:

The Contract Price does not include any additional labor and / or materials required to perform the Work due to unknown obstructions including, but not limited to, underground utilities, rock, granite or concrete.

Seller shall, upon discovery of such obstructions, promptly notify Buyer of the condition. Buyer shall pay any extra costs caused by the obstruction in order to complete the Work. Costs will be billed on a time and material basis with a 15% markup for overhead and profit.

At its option to minimize costs, Buyer may elect to change the location of product installation.



# THE AMERICAN INSTITUTE OF ARCHITECTS

Bond No. 2020073M

## AIA Document A310 Bid Bond

KNOW ALL MEN BY THESE PRESENTS, THAT WE Hilton Displays, LLC  
125 Hillside Drive, Greenville, SC 29607

as Principal, hereinafter called the Principal, and Platte River Insurance Company  
PO Box 5900, Madison, WI 53705

a corporation duly organized under the laws of the State of NE  
as Surety, hereinafter called the Surety, are held and firmly bound unto City of Dover, New Hampshire  
288 Central Avenue, Dover, NH 03820

as Obligee, hereinafter called the Obligee, in the sum of Ten Percent of Amount Bid  
Dollars (\$ 10% ),  
for the payment of which sum well and truly to be made, the said Principal and the said Surety, bind ourselves, our heirs, executors, administrators, successors and assigns, jointly and severally, firmly by these presents.

WHEREAS, the Principal has submitted a bid for RFP # B20048- Wayfinding and Informational System; City of Dover,  
New Hampshire.

NOW, THEREFORE, if the Obligee shall accept the bid of the Principal and the Principal shall enter into a Contract with the Obligee in accordance with the terms of such bid, and give such bond or bonds as may be specified in the bidding or Contract Documents with good and sufficient surety for the faithful performance of such Contract and for the prompt payment of labor and materials furnished in the prosecution thereof, or in the event of the failure of the Principal to enter such Contract and give such bond or bonds, if the Principal shall pay to the Obligee the difference not to exceed the penalty hereof between the amount specified in said bid and such larger amount for which the Obligee may in good faith contract with another party to perform the Work covered by said bid, then this obligation shall be null and void, otherwise to remain in full force and effect.

Signed and sealed this 24th day of March, 2020

Adam C. Lusk  
(Witness)

Hilton Displays, LLC  
(Principal) (Seal)  
By: [Signature] Treasurer  
(Title)

J. Mishoe  
Jessica Mishoe (Witness)

Platte River Insurance Company  
(Surety) (Seal)  
By: Lauren Brasher  
Attorney-in-Fact Lauren Brasher (Title)



PLATTE RIVER INSURANCE COMPANY  
POWER OF ATTORNEY

41421361

KNOW ALL MEN BY THESE PRESENTS, That the PLATTE RIVER INSURANCE COMPANY, a corporation of the State of Nebraska, having its principal offices in the City of Middleton, Wisconsin, does make, constitute and appoint

-----CHARLES D. WELCH; LAUREN BRASHIER; JUSTIN BENJAMIN-----

its true and lawful Attorney(s)-in-fact, to make, execute, seal and deliver for and on its behalf, as surety, and as its act and deed, any and all bonds, undertakings and contracts of suretyship, provided that no bond or undertaking or contract of suretyship executed under this authority shall exceed in amount the sum of

-----ALL WRITTEN INSTRUMENTS IN AN AMOUNT NOT TO EXCEED \$20,000,000.00-----

This Power of Attorney is granted and is signed and sealed by facsimile under and by the authority of the following Resolution adopted by the Board of Directors of PLATTE RIVER INSURANCE COMPANY at a meeting duly called and held on the 8th day of January, 2002.

“RESOLVED, that the President, Executive Vice President, Vice President, Secretary or Treasurer, acting individually or otherwise, be and they hereby are granted the power and authorization to appoint by a Power of Attorney for the purposes only of executing and attesting bonds and undertakings, and other writings obligatory in the nature thereof, one or more resident vice-presidents, assistant secretaries and attorney(s)-in-fact, each appointee to have the powers and duties usual to such offices to the business of this company; the signature of such officers and seal of the Company may be affixed to any such power of attorney or to any certificate relating thereto by facsimile, and any such power of attorney or certificate bearing such facsimile signatures or facsimile seal shall be valid and binding upon the Company, and any such power so executed and certified by facsimile signatures and facsimile seal shall be valid and binding upon the Company in the future with respect to any bond or undertaking or other writing obligatory in the nature thereof to which it is attached. Any such appointment may be revoked, for cause, or without cause, by any of said officers, at any time.”

In connection with obligations in favor of the Florida Department of Transportation only, it is agreed that the power and authority hereby given to the Attorney-in-Fact includes any and all consents for the release of retained percentages and/or final estimates on engineering and construction contracts required by the State of Florida Department of Transportation. It is fully understood that consenting to the State of Florida Department of Transportation making payment of the final estimate to the Contractor and/or its assignee, shall not relieve this surety company of any of its obligations under its bond.

In connection with obligations in favor of the Kentucky Department of Highways only, it is agreed that the power and authority hereby given to the Attorney-in-Fact cannot be modified or revoked unless prior written personal notice of such intent has been given to the Commissioner – Department of Highways of the Commonwealth of Kentucky at least thirty (30) days prior to the modification or revocation.

IN WITNESS WHEREOF, the PLATTE RIVER INSURANCE COMPANY has caused these presents to be signed by its officer undersigned and its corporate seal to be hereto affixed duly attested, this 3rd day of May, 2017.

Attest:

*John E. Rzepinski*

John E. Rzepinski  
Vice President, Treasurer & CFO

*Suzanne M. Broadbent*

Suzanne M. Broadbent  
Assistant Secretary

STATE OF WISCONSIN }  
COUNTY OF DANE } s.s.:



PLATTE RIVER INSURANCE COMPANY

*Stephen J. Sills*

Stephen J. Sills  
CEO & President

On the 3<sup>rd</sup> day of May, 2017 before me personally came Stephen J. Sills, to me known, who being by me duly sworn, did depose and say: that he resides in the County of New York, State of New York; that he is President of PLATTE RIVER INSURANCE COMPANY, the corporation described in and which executed the above instrument; that he knows the seal of the said corporation; that the seal affixed to said instrument is such corporate seal; that it was so affixed by order of the Board of Directors of said corporation and that he signed his name thereto by like order.

STATE OF WISCONSIN }  
COUNTY OF DANE } s.s.:

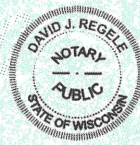

*David J. Regele*

David J. Regele  
Notary Public, Dane Co., WI  
My Commission Is Permanent

I, the undersigned, duly elected to the office stated below, now the incumbent in PLATTE RIVER INSURANCE COMPANY, a Nebraska Corporation, authorized to make this certificate, DO HEREBY CERTIFY that the foregoing attached Power of Attorney remains in full force and has not been revoked; and furthermore, that the Resolution of the Board of Directors, set forth in the Power of Attorney is now in force.

Signed and sealed at the City of Middleton, State of Wisconsin this 24 day of March, 20 20



*Antonio Celii*

Antonio Celii  
General Counsel, Vice President & Secretary





**Hilton Displays, Inc. and its subcontractors understand what is required by this Request for Proposal. Specifically, the proposal incorporates the following scope of work to be completed by July 15<sup>th</sup> of 2020:**

- Manufacture of Identification, information, directional and interpretive signs, including aluminum panel signs, post and panel signs, vertical columns, painted and vinyl applied graphics; sign system of non-illuminated elements per the design file supplied along with the 5 subsequent addendums. This is to include any specialty attachments, fixtures, hardware, and accessories as indicated.
- Preparation of foundations for and site work related to installation of new exterior signs will be performed by Contractor.
- Installation of signage as indicated per the pricing matrix and design files, along with accompanying addendums.
- Electrical work is outside of the scope of this proposal as none of the signs is/are illuminated.
- Removal of any existing signs is the responsibility of the City of Dover.
- Per the design files and subsequent addendums, certain prototypes will need to be supplied for City approval.





## **Fabrication-Installation Approach/Process – City of Dover, NH Wayfinding**

Being firmly committed to achieving project completion by July 15<sup>th</sup>, 2020, we present the following "Approach/Process" . . .

- **Once Hilton Displays receives some form of Notice to Proceed, our approach/process is as follows:**
  - If not already completed, a Site Survey is performed, including staking and photographing locations
  - Shop Drawings, Scaled Layouts and Message Schedule creation commences
  - Required Color and Material Sample production commences
  
- **Once complete, Submittals are sent to stakeholders for review and approval. Any required revisions are completed and re-submitted. Once final approval is received:**
  - Any necessary permits are procured
  - Non-stock materials are purchased
  
- **Once Permits are in-hand:**
  - Fabrication commences
  - Any required prototypes/first articles are produced and submitted for review and approval
  
- **Toward completion of Fabrication:**
  - Site preparation begins
  - Location-staking is finalized
  
- **Once signs begin Shipping to site:**
  - Footer excavation begins
  - Placement of any rebar, pouring of concrete and setting of anchors begins
  
- **Upon Delivery of signs:**
  - Signs are set on and bolted down to foundations
  - Signs being installed on existing poles and/or structures are mounted
  
- **Punchlist is performed and corrections made**



## Company Profile

### History

Hilton Displays, LLC was founded in 1981 to fulfill the specialized needs of clients demanding detailed attention and superior service for their brand implementation and maintenance needs. Our steady growth has been fueled by our personal commitment to our client base and the professional relationships that have grown from the trust that those customers have placed in Hilton Displays. It is this same client base that has provided us with the opportunity to evolve into one of the premier brand implementation providers.

Headquartered in Greenville, SC, we operate from a 60,000 square foot manufacturing facility equipped with current technology and capital equipment. From this facility we provide the following services:

- Code Check
- Branding Surveys
- Technical Surveys
- Design
- Engineering
- Cost Estimates
- Prototyping
- Value Engineering
- Program Management
- Manufacturing
- Logistics
- Installation
- Service & Maintenance
- Leasing



## Customers

Our customer base includes financial institutions, national retailers, healthcare organizations, colleges and universities, entertainment venues, design firms, management companies responsible for corporate branding, architects, general contractors, and sign consultants.

We provide our customers with the best products and services, and will maintain our competitive advantage by:

- Always putting our customer first
- Providing an unsurpassed level of service
- Listening and being responsive to customer needs
- Exceeding expectation by providing the highest level of service and product quality in the industry

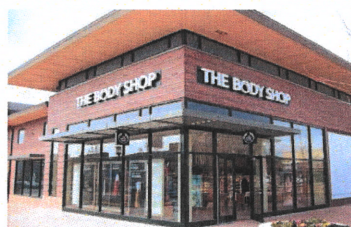

**HILTONDISPLAYS**  
GREAT SIGNS FOR GREAT COMPANIES



# SPECIALTY PROJECTS PHOTOS



## Miracle Marketplace

A Retail Project



**HILTONDISPLAYS**  
GREAT SIGNS FOR GREAT COMPANIES



# SPECIALTY PROJECTS PHOTOS

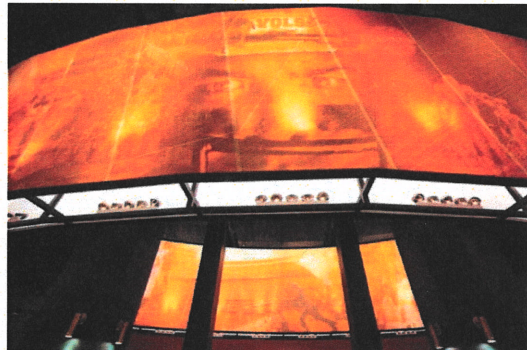
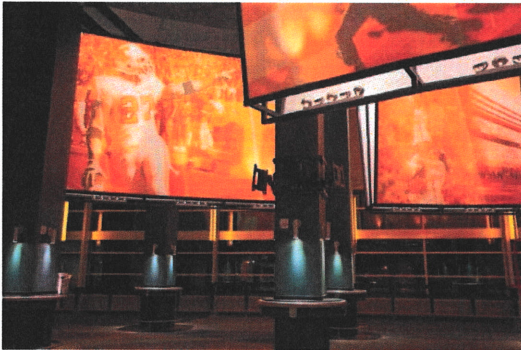

**HILTONDISPLAYS**  
GREAT SIGNS FOR GREAT COMPANIES





# **High-Angle Installation**





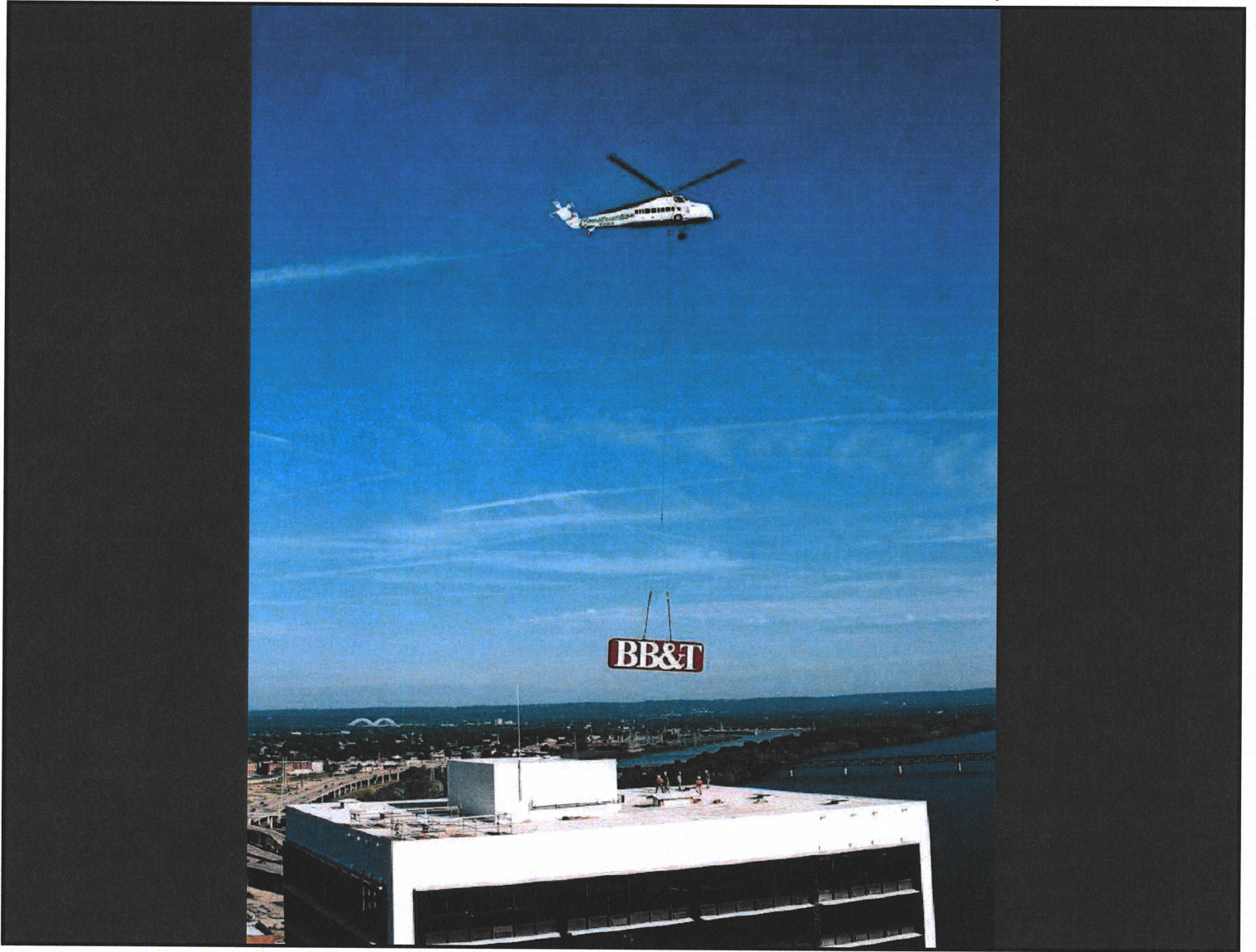



**BB&T**

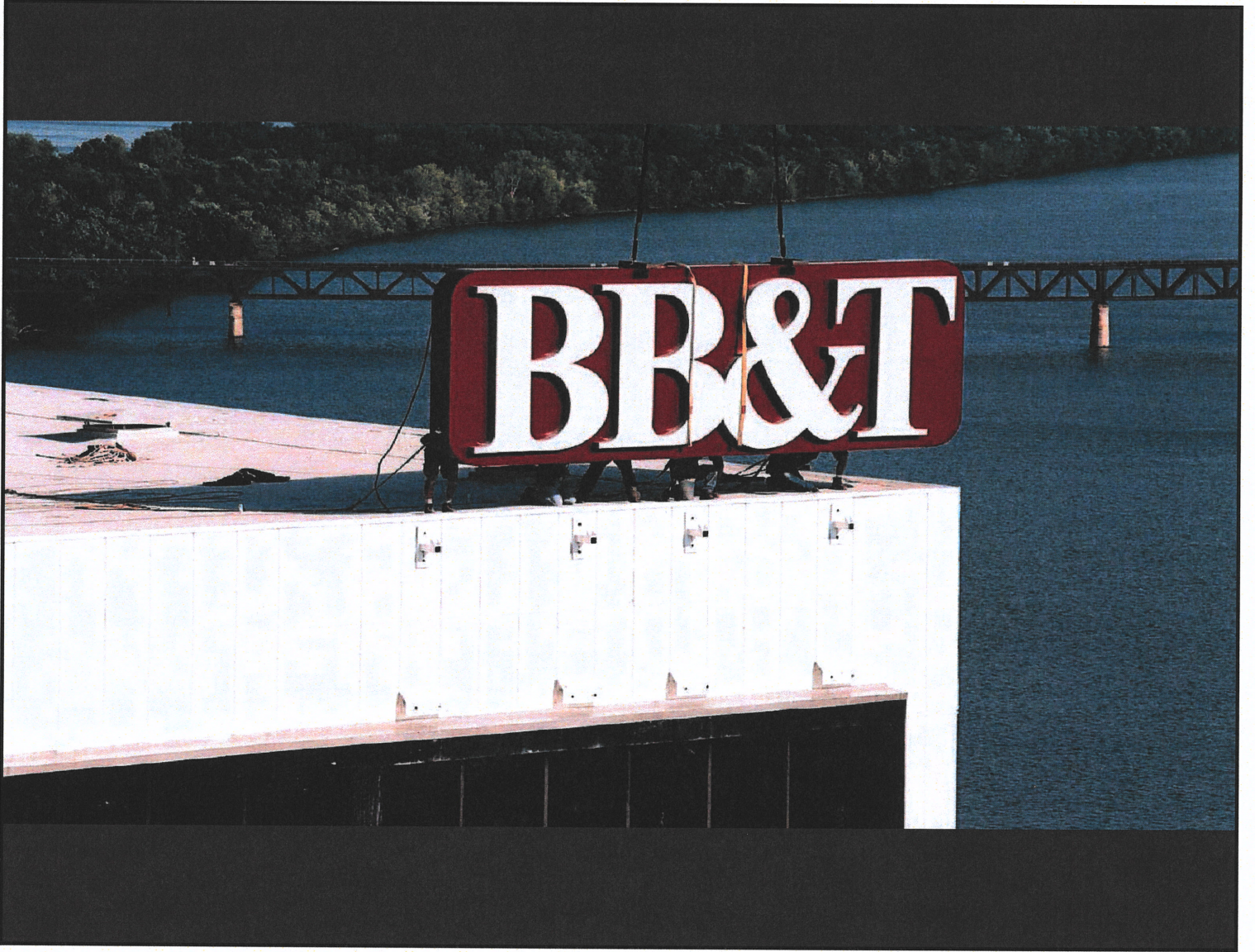























# NATIONAL BRANDING PHOTOS

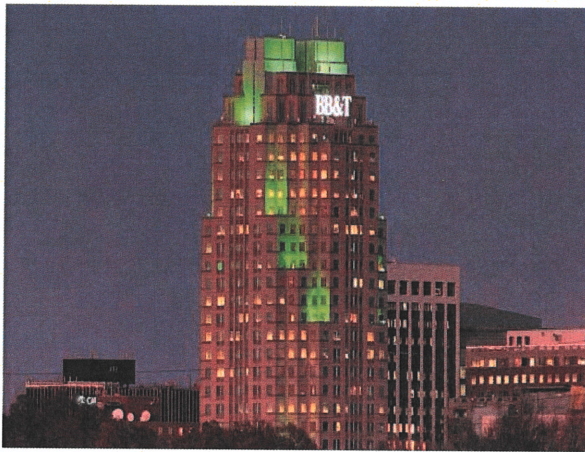



# NATIONAL BRANDING PHOTOS



**~~HILTON~~DISPLAYS**  
GREAT SIGNS FOR GREAT COMPANIES



# Affiliations

ISA



USSC



SEGD



Sign Search

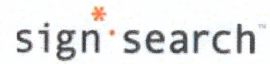

Chamber(s)  
of Commerce



PMI



Southeast Sign  
Association





Hilton Displays, LLC Team Org Chart - City of Dover, NH Wayfinding

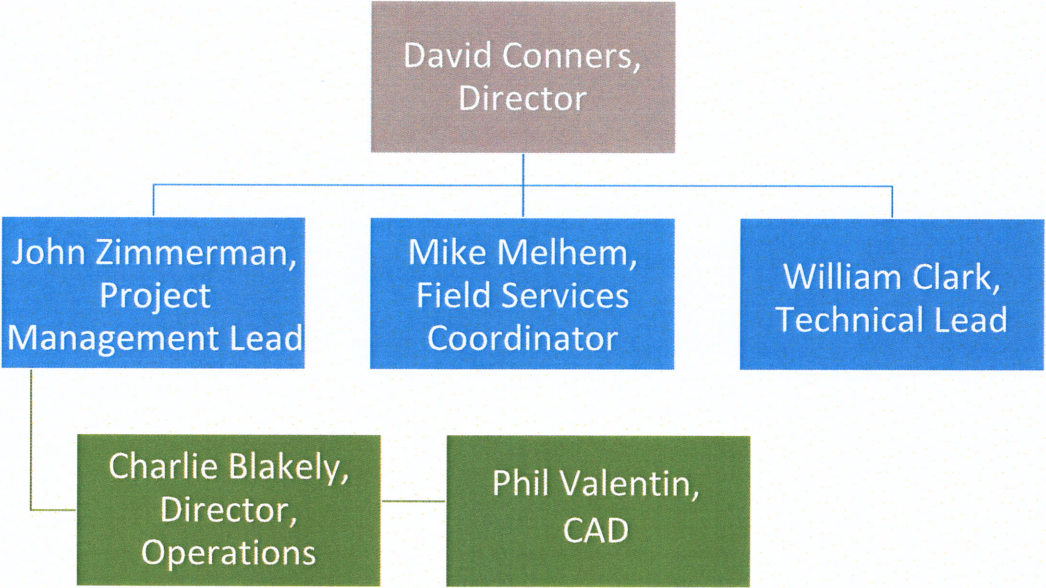





**SUBCONTRACTOR SERVICES**

Hilton Displays, Inc. will utilize the installation services of C&S Signs out of Manchester, NH.

**C&S Signs**  
**59 Sargent Rd**  
**Manchester, NH 03103**  
**Phone: (603) 231-3602**  
**[www.cssignsusa.com](http://www.cssignsusa.com)**





**Department of Public Works**

**Re: Hilton Displays Letter of Recommendation**

To Whom It May Concern,

I have had the distinct privilege of working with Wayne Rhodes and Hilton Displays over the last several months on a wayfinding signage project for our new 18,000 seat Intrust Bank Arena in downtown Wichita. Hilton was able to provide a high quality product on-time and well under our original budget. The timeframe available for fabrication and installation on this project was very short, yet Hilton was able to deliver in-spite of significant weather restrictions as the Arena opening approached.

Mr. Rhodes' leadership on behalf of Hilton was undoubtedly a driving factor in the success of this project. His technical expertise in helping resolve problems with dynamic message signs installed with the project has been invaluable. I can easily say that Wayne has been more accommodating during the course of this project than any contractor I have had the pleasure of working with during my 15 year career.

The Intrust Bank Arena's first event was held on Saturday, January 9, a sold-out concert by Brad Paisley. The public and all involved were most complimentary about the signage and the positive impact on making parking much easier than expected.

I would highly recommend Hilton Displays to any community looking for a very qualified and capable sign company. We certainly hope to have the chance to work with them again in the future.

Sincerely,

Gary Janzen, P.E.  
Chief Design Engineer

**Engineering Division**



## Wayfinding Project References

Project name:	<b>Consol Energy Center</b>
Description of work:	Branding & Wayfinding Signage for 300-million-dollar arena in Pittsburgh
Contract delivery method:	CM
Owners name / Representative:	Brian Magness - Pittsburgh Penguins
Owner Phone:	Console Energy Center, 412-642-1800
Architect:	Populous
Architect Address	4800 Main Street, Suite 300, Kansas City, MO 64112
CM Name / Representative:	PJ Dick
CM address / Phone / Email:	Theresa M McCue / 412-807-2000
Contract dollar value:	\$450,000
Project name:	<b>Intrust Bank Arena</b>
Description of work:	Exterior Wayfinding for downtown arena
Contract delivery method:	CM
Owners name / Representative:	Gary Janzen, P.E. - Chief Design Engineer
Owner Address / Phone / Email:	City of Wichita, 455 N Main, 8th Floor, Wichita, KS 67202 / 316-262-6000
CM Name / Representative:	Gary Janzen, P.E. - Chief Design Engineer
CM Address / Phone / Email:	455 N Main, 8th Floor, Wichita, KS 67202 / 316-262-6000
Contract dollar value:	\$250,000
Project name:	<b>Miracle Plaza</b>
Description of work:	Branding and Wayfinding Signage for retail center
Contract delivery method:	CM
Owner's Representative:	Don Tupper
Owner Address / Phone / Email:	3301 Coral Way, Miami, FL 33145 - 305.443.9620
Architect Name / Representative:	TGA Design / David Stuart <a href="mailto:David_Stuart@TGADesign.com">David_Stuart@TGADesign.com</a>
Architect Address / Phone:	4649 Ponce de Leon Blvd, Suite 401, Coral Gables, FL 33146 / 305-669-2550
CM Address / Phone:	Talisman Co, 355 Alhambra Circle, Coral Gables, FL 33134 / 305-662-9559
Contract dollar value:	\$303,315



# ~~HILTON~~DISPLAYS

**Name:** Old Dominion University Stadium Signage

**Scope:** Main ID, Site ID, Directional, Directories, Team Store, Concessions, Section ID and Room ID Signage

**Value:** \$350,000.00





# ~~HILTON~~DISPLAYS

**Name:** East Chicago, Indiana Gateway Signage

**Scope:** 3 Large Gateway Signs for City

**Value:** \$105,000.00

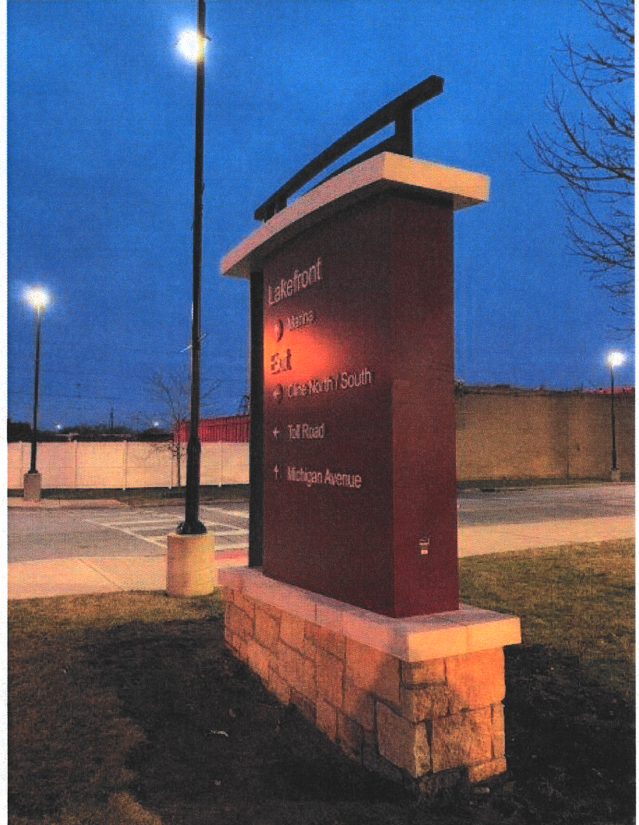
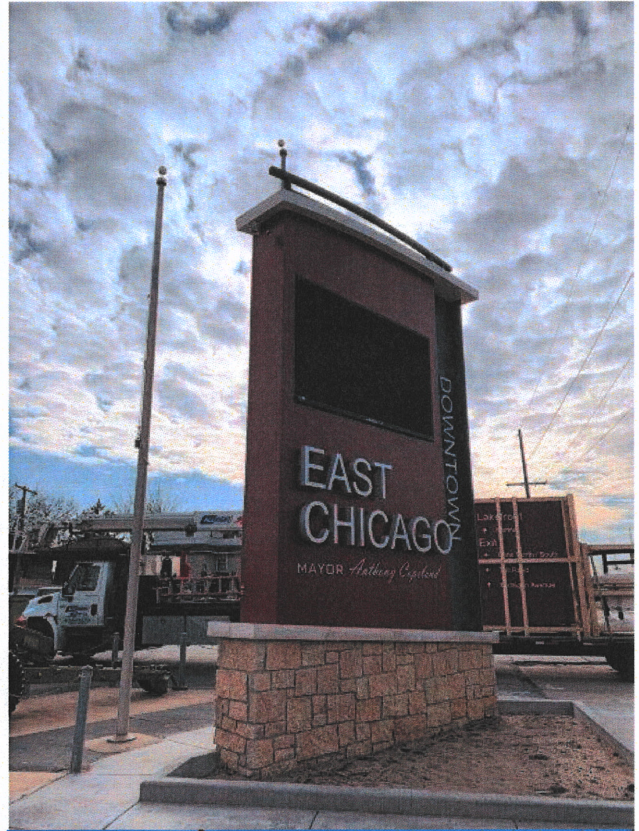



# ~~HILTONDISPLAYS~~

**Name:** Elizabethtown Community & Technical College Campus Signage

**Scope:** Building ID and Directional Signage

**Value:** \$110,000.00

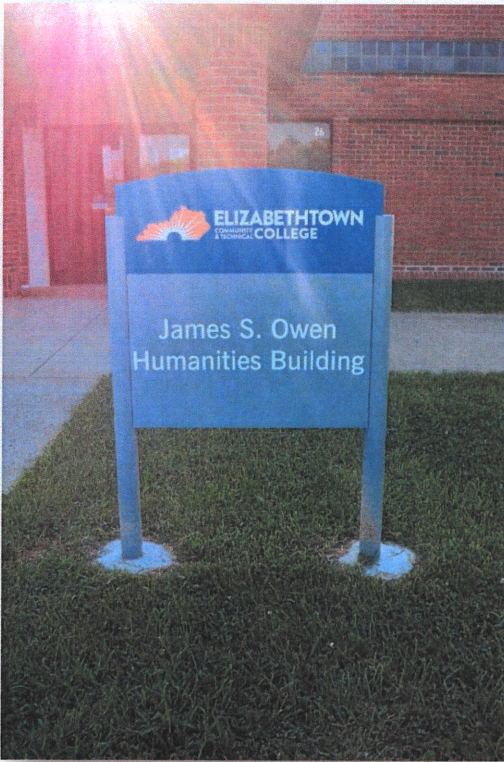



---

**2019**



CITY OF

**CAÑON CITY**

**Brand Book**

City of Cañon City  
Cañon City, CO

**QID# 19-48023**

**SIGN TYPE A.3**  
**GATEWAY MONUMENT**

**Designer:**  
Greg Sloan

**Date:**  
1-13-2020

---

**HILTONDISPLAYS**  
GREAT SIGNS FOR GREAT COMPANIES

125 Hillside Drive Greenville, South Carolina 29607

Phone: 864-233-0401

National Toll Free: (800) 353-9132

[www.hiltondisplays.com](http://www.hiltondisplays.com)



# Color Palette

PANTONE / VINYL / PAINT

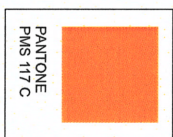
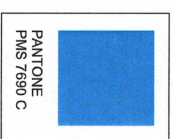
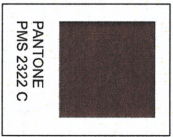

**P-1 PAINT**  
MR 62016 EBONY GOLD  
METALLIC (SATIN FINISH)

**P-2 PAINT**  
MR 6668 SILVER  
METALLIC (SATIN FINISH)

**P-3 PAINT**  
MR 61019 TONAL BLUE  
(SATIN FINISH)

**P-4 DIGITAL PRINT**  
ON 3M 3590DS HIGH  
INTENSITY PRISMATIC  
REFLECTIVE SHEETING

**D-1 DIGITAL PRINT**  
ON 3M 3590DS HIGH  
INTENSITY PRISMATIC  
REFLECTIVE SHEETING

**D-2 DIGITAL PRINT**  
ON 3M 3590DS HIGH  
INTENSITY PRISMATIC  
REFLECTIVE SHEETING

**D-4 DIGITAL PRINT**  
ON 3M 3590DS HIGH  
INTENSITY PRISMATIC  
REFLECTIVE SHEETING

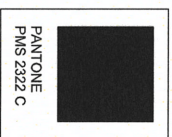
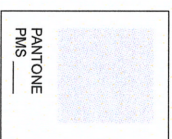
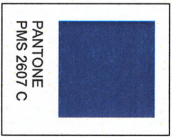

**D-3 DIGITAL PRINT**  
ON 3M 3590DS HIGH  
INTENSITY PRISMATIC  
REFLECTIVE SHEETING

**D-5 DIGITAL PRINT**  
ON 3M 3590DS HIGH  
INTENSITY PRISMATIC  
REFLECTIVE SHEETING

**V-2 VINYL GRAPHICS**  
3M 3655-70 / 60%  
DIFFUSER FILM

**P-4 PAINT**  
MR 39653 BLACK  
STALLON (SATIN FINISH)



CORTEN STEEL

**NOTE:**  
Color and Typography specifications shown are for all signage and graphics contained within the overall site design package. Not all colors and/or fonts are used for each individual sign type included herein.

# Typography

P2 OF 9

CLEARVIEW HIGHWAY 5-W-R / Normal

**A B C D E F G H I J K L M N O P Q R S T U V W X Y Z**  
**abcdefghijklmnopqrstuvwxyz**  
**1234567890&?**

SENTINEL / Bold

**A B C D E F G H I J K L M N O P Q R S T U V W X Y Z**  
**abcdefghijklmnopqrstuvwxyz**  
**0 1 2 3 4 5 6 7 8 9 Ñ ñ**

# Symbols



HOSPITAL



PARKING

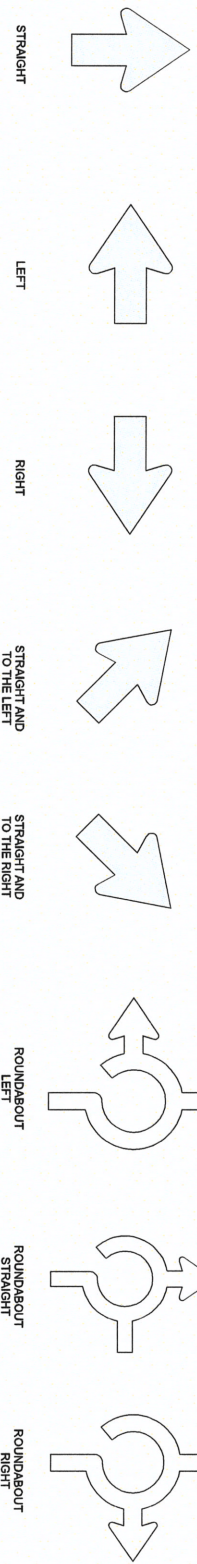

STRAIGHT

LEFT

RIGHT

STRAIGHT AND TO THE LEFT

STRAIGHT AND TO THE RIGHT

ROUNDAABOUT LEFT

ROUNDAABOUT STRAIGHT

ROUNDAABOUT RIGHT

THIS DESIGN IS THE ORIGINAL AND UNPUBLISHED WORK OF HILTON DESIGN AND MAY NOT BE REPRODUCED, COPIED, OR EMULATED IN ANY MANNER WITHOUT WRITTEN CONSENT FROM AN AUTHORIZED OFFICER OF THE COMPANY. © HILTON DESIGN 2020

**HILTON DESIGN PLANS**  
125 HILLSIDE DRIVE • GREENVILLE SC 29607  
P 800 333 9132 • F 864 242 2204  
www.hiltondesignplans.com

**QID 19-48023**

JOB NAME

City of Cañon City

LOCATION

Cañon City, CO

CUSTOMER CONTACT

SALESMAN / PM  
Mike Melham

DESIGNER  
Greg Sloan

DWG. DATE  
1-06-2020

REV. DATE / REVISION  
1-13-2020

SCALE

FILE

2019/City of Cañon City/  
Cañon City/  
19-48023/

DESIGN SPECIFICATIONS ACCEPTED BY:

EST. CLIENT:

SUPPLIER LANDLORD:







125 Hillside Drive Greenville, South Carolina 29607

Phone: 864-233-0401

National Toll Free: (800) 353-9132

www.hiltondisplays.com

OIDD / 19-48023

# SIGN TYPE A.3 | DESIGNATION GATEWAY MONUMENT

QTY. 2

## MATHEMS PAINT

- P1: MP2016 Ebony Gold Met., satin
- P2: MP5868 Sursel Silver Met., satin
- P3: MP10359 Tonal Blue
- P4: MP35653 Black Stallion, satin

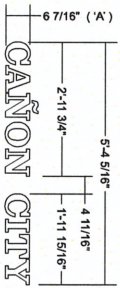

1A Channel Letters  
SCALE: 3/8" = 1'-0"

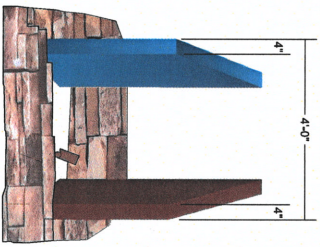

2 Side Elevation  
SCALE: 3/8" = 1'-0"

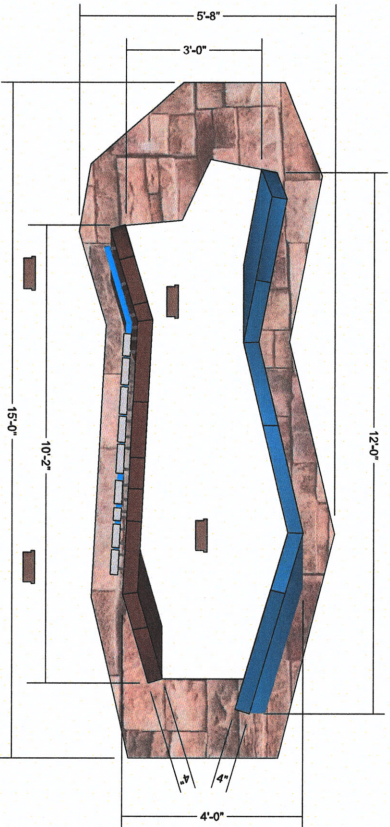

1 Top Elevation - A.3  
SCALE: 3/8" = 1'-0"

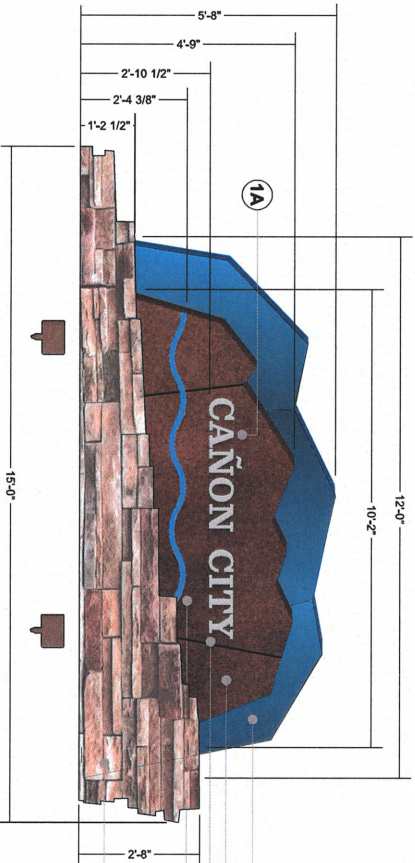

3 Front Elevation - A.3  
SCALE: 3/8" = 1'-0"



QTY. 4 (per sign) PLT-50183 50W 5000K LED Flood lights with U-10V dimming, knuckle attachment (for angle adjustment), and a 120v/27V universal voltage, Dark Bronze finish.

All wiring and spacing / setback to be per manufacturers specifications.

**NOTES:**  
Power Supply to sign location to be line voltage provided by city. Engineer to evaluate gateway panels for additional structural bracing between panels, if required.

Gateway - background panel:  
4" deep, 1/2" fabricated aluminum with internal tube frame construction. Internal structural support posts w/ external match plates to connect to stone above grade. Foundation to be set level with grade.  
Paint: P3 - all surfaces

Gateway - front panel:  
1/2" thick fabricated aluminum with internal tube frame construction. 1/2" Corrugated steel (sawed) attached to structure using 1/2" fasteners and gasketing at all material connection points. Internal structural support posts w/ external match plates to connect to looker, above grade. Foundation to be set level with grade.

2" thick halo-illuminated stainless steel channel letters.  
FONT: Sentinel Bold  
Paint: P2 - All Surfaces

1 1/2" deep halo-illuminated welded aluminum "tree" shape.  
Face and returns painted P-3

Stacked Ashlar Sileam (quilt) sandstone. Stone to be locally sourced. (Stone should not be red or similar to flagstaff sandstone)  
Stonework setting will be approved on-site with contractor at the time of installation.



**SIGN TYPE A.3** | DESIGNATION  
A.3-01 / A.3-02  
**GATEWAY MONUMENT**

**MATTHEWS PAINT**

- P1: MP02016 Ebony Gold Mel., satin
- P2: MP56869 Sunset Silver Mel., satin
- P3: MP10359 Tonal Blue
- P4: MP33653 Black Stallion, satin

**DIGITAL PRINT**

- D1: PMS 2322 C Brown
- D2: PMS 117 C Gold
- D3: PMS 2807 C Purple
- D4: PMS 7890 C Blue
- D5: PMS 7842 C Blue

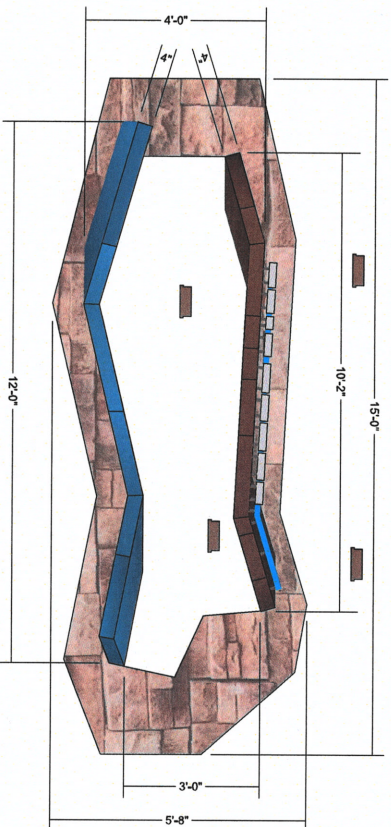

1 Top Elevation - A.3  
SCALE: 3/8" = 1'-0"

Gateway - background panel:  
4" deep .125" fabricated aluminum with internal tube frame construction.  
Internal structural support posts w/ external match plates to connect to footer, above grade. Foundation to be set level with grade.  
Paint P3 - all surfaces

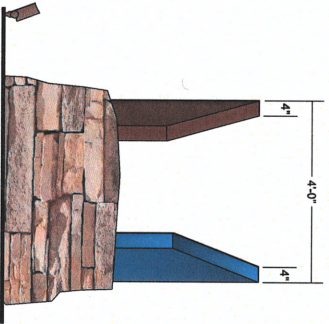

2 Side Elevation  
SCALE: 3/8" = 1'-0"

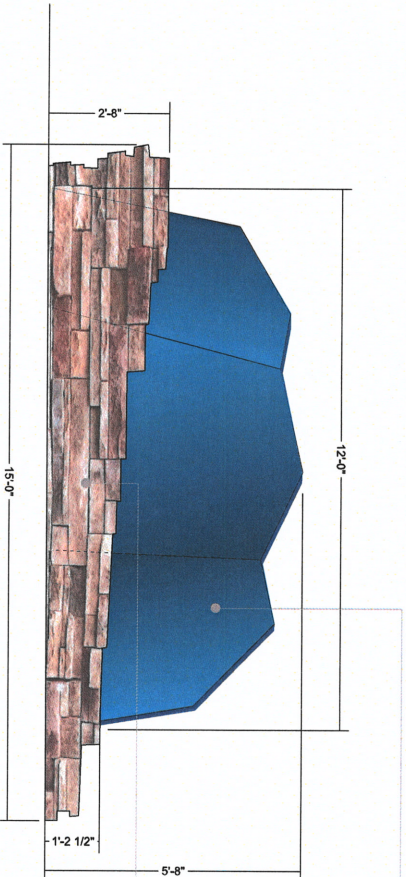

3 Front Elevation - A.3  
SCALE: 3/8" = 1'-0"

Stacked Ashlar Shoam (buff) sandstone. Stone to be locally sourced.  
(Stone should not be red or similar to flagstaff sandstone)  
Stonework setting will be approved on-site with contractor at the time of installation.





P5 OF 9

2019

125 Hillside Drive Greenville, South Carolina 29607

Phone: 864-233-0401

National Toll Free: (800) 353-9132

[www.hiltondisplays.com](http://www.hiltondisplays.com)

OID / 19-48023



THIS DESIGN IS THE ORIGINAL AND UNPUBLISHED WORK OF HILTON DISPLAYS AND MAY NOT BE REPRODUCED, COPIED, OR EXHIBITED IN ANY FASHION WITHOUT WRITTEN CONSENT FROM AN AUTHORIZED OFFICER OF THE COMPANY. © HILTON DISPLAYS 2019



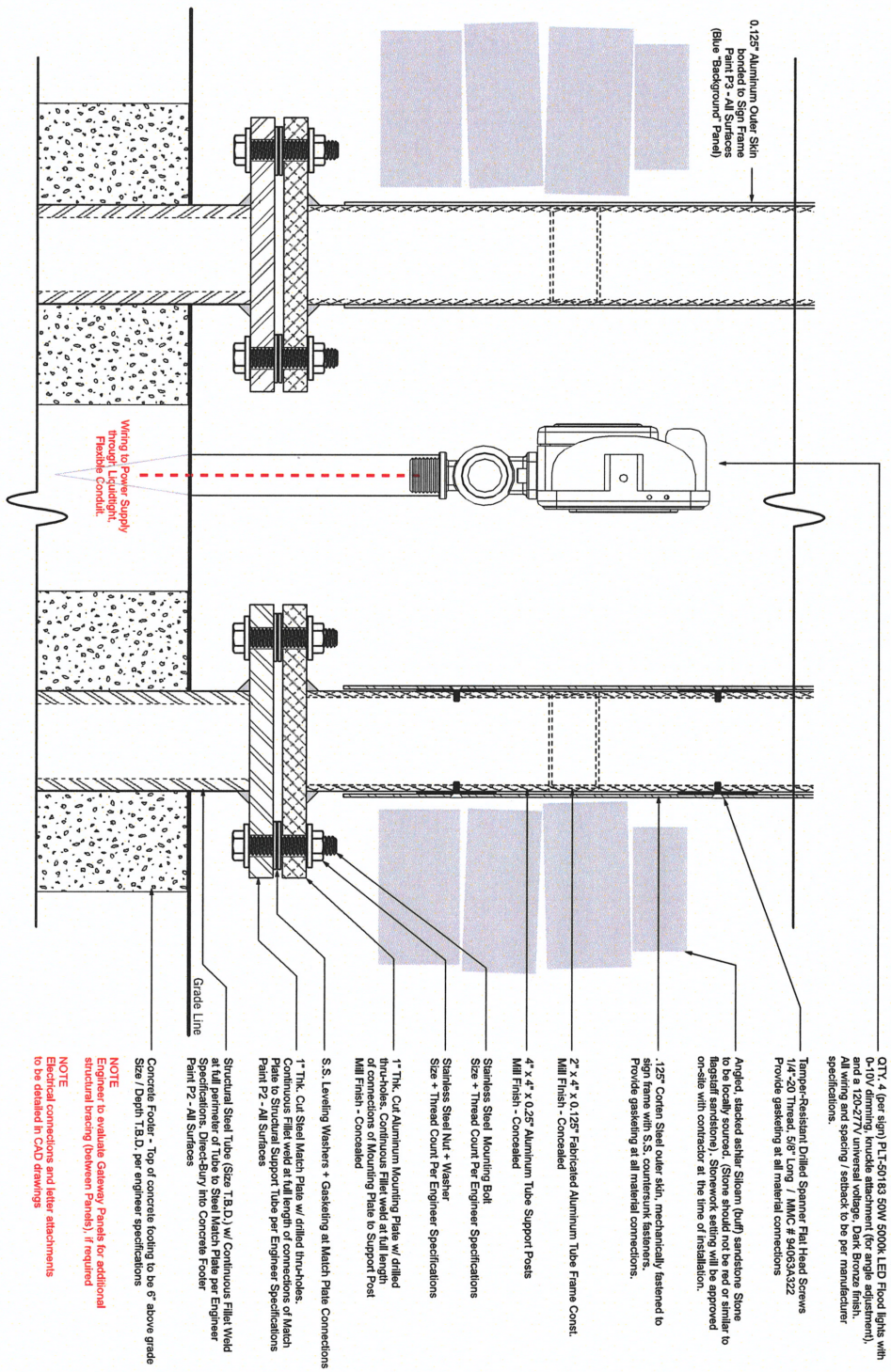

1 Construction Detail - Typical - Base / Footer Connection  
SCALE: 3/4" = 1'

THIS DESIGN IS THE ORIGINAL AND UNPUBLISHED WORK OF HILTON DISPLAYS AND MAY NOT BE REPRODUCED, COPIED, OR EXHIBITED IN ANY MANNER WITHOUT WRITTEN CONSENT FROM AN AUTHORIZED OFFICER OF THE COMPANY. © HILTON DISPLAYS 2020



Job # 172, 3701, 20  
 Project City of Canon City - Sign Cabinet A.A.  
 Job Location Intersection of US 161 S.W. Hwy 50, Fremont Dr. & N. Hwy B  
 City of Canon City, CO

Notes:  
 1. Express envelope (B, C or D)  
 2. Impulse factor (p. 77, 6.07, 1.0 or 1.15)  
 3. Basic wind speed (2 sec. gust wind)  
 4. Topographic factor (see 6.5.2, p. 82 or 6.49)  
 5. Exposure category (see 6.5.3, p. 82 or 6.49)  
 6. Height factor (see 6.5.4, p. 82 or 6.49)  
 7. Directional factor (see 6.5.5, p. 82 or 6.49)  
 8. Gust effect factor (see 6.5.6, p. 82 or 6.49)  
 9. Direction of pressure (see 6.5.7, p. 82 or 6.49)  
 10. Direction of suction (see 6.5.8, p. 82 or 6.49)  
 11. Minimum design wind speed (see 6.5.9, p. 82 or 6.49)  
 12. Minimum design suction (see 6.5.10, p. 82 or 6.49)

WIND SPEED	WIND PRESSURE	WIND SUCTION
1	160 psf	120 psf
2	180 psf	135 psf
3	200 psf	150 psf
4	220 psf	165 psf
5	240 psf	180 psf
6	260 psf	195 psf
7	280 psf	210 psf
8	300 psf	225 psf
9	320 psf	240 psf
10	340 psf	255 psf
11	360 psf	270 psf
12	380 psf	285 psf
13	400 psf	300 psf
14	420 psf	315 psf
15	440 psf	330 psf
16	460 psf	345 psf
17	480 psf	360 psf
18	500 psf	375 psf
19	520 psf	390 psf
20	540 psf	405 psf
21	560 psf	420 psf
22	580 psf	435 psf
23	600 psf	450 psf
24	620 psf	465 psf
25	640 psf	480 psf
26	660 psf	495 psf
27	680 psf	510 psf
28	700 psf	525 psf
29	720 psf	540 psf
30	740 psf	555 psf
31	760 psf	570 psf
32	780 psf	585 psf
33	800 psf	600 psf
34	820 psf	615 psf
35	840 psf	630 psf
36	860 psf	645 psf
37	880 psf	660 psf
38	900 psf	675 psf
39	920 psf	690 psf
40	940 psf	705 psf
41	960 psf	720 psf
42	980 psf	735 psf
43	1000 psf	750 psf
44	1020 psf	765 psf
45	1040 psf	780 psf
46	1060 psf	795 psf
47	1080 psf	810 psf
48	1100 psf	825 psf
49	1120 psf	840 psf
50	1140 psf	855 psf
51	1160 psf	870 psf
52	1180 psf	885 psf
53	1200 psf	900 psf
54	1220 psf	915 psf
55	1240 psf	930 psf
56	1260 psf	945 psf
57	1280 psf	960 psf
58	1300 psf	975 psf
59	1320 psf	990 psf
60	1340 psf	1005 psf
61	1360 psf	1020 psf
62	1380 psf	1035 psf
63	1400 psf	1050 psf
64	1420 psf	1065 psf
65	1440 psf	1080 psf
66	1460 psf	1095 psf
67	1480 psf	1110 psf
68	1500 psf	1125 psf
69	1520 psf	1140 psf
70	1540 psf	1155 psf
71	1560 psf	1170 psf
72	1580 psf	1185 psf
73	1600 psf	1200 psf
74	1620 psf	1215 psf
75	1640 psf	1230 psf
76	1660 psf	1245 psf
77	1680 psf	1260 psf
78	1700 psf	1275 psf
79	1720 psf	1290 psf
80	1740 psf	1305 psf
81	1760 psf	1320 psf
82	1780 psf	1335 psf
83	1800 psf	1350 psf
84	1820 psf	1365 psf
85	1840 psf	1380 psf
86	1860 psf	1395 psf
87	1880 psf	1410 psf
88	1900 psf	1425 psf
89	1920 psf	1440 psf
90	1940 psf	1455 psf
91	1960 psf	1470 psf
92	1980 psf	1485 psf
93	2000 psf	1500 psf
94	2020 psf	1515 psf
95	2040 psf	1530 psf
96	2060 psf	1545 psf
97	2080 psf	1560 psf
98	2100 psf	1575 psf
99	2120 psf	1590 psf
100	2140 psf	1605 psf

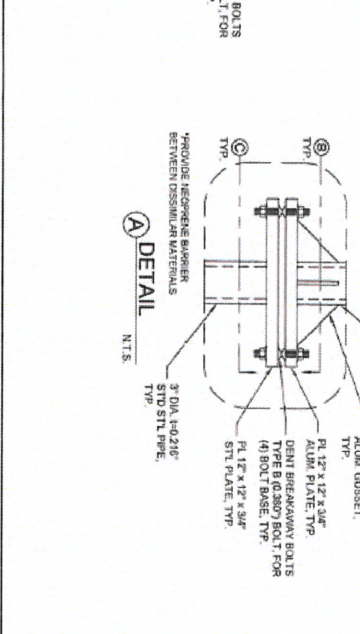
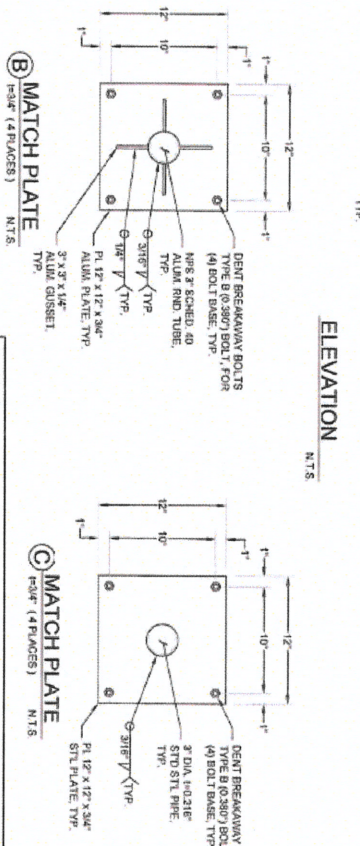
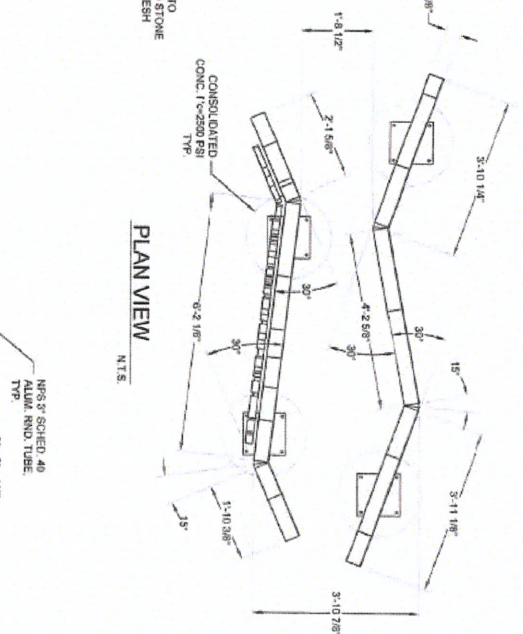
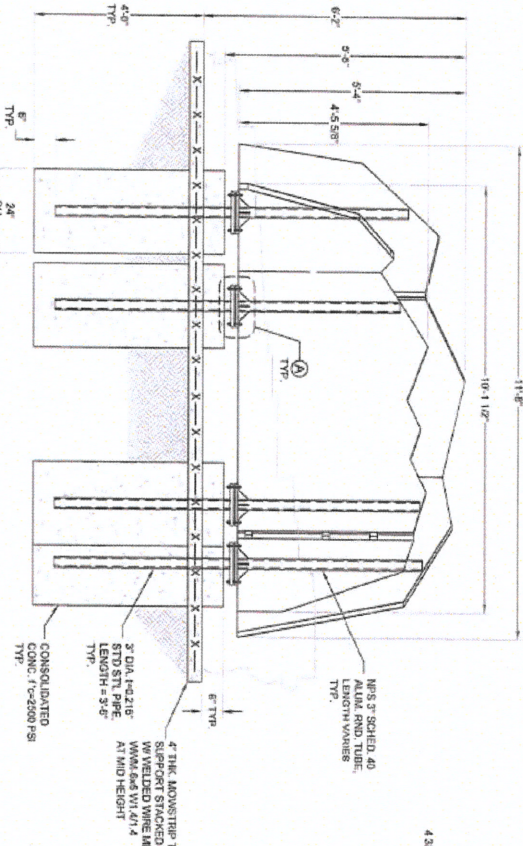

www.jpc.com  
 P.O. Box 80250  
 Santa Clara, CA 91380  
 Tel: (651)253-0700 Fax: (651)253-0900

2/3/2020  
 SHEET TITLE

**CITY OF CANON CITY  
 SIGN CABINET A.3**

**NOTES:**  
 GENERAL:  
 - SIGN DESIGN IS BASED ON ADEQUATE EXISTING SUPPORT ELEMENTS  
 - PROVIDE ISOLATION OF DISSIMILAR MATERIALS.  
 - COAT ALUMINUM IN CONTACT WITH CONCRETE WITH ZINC RICH PAINT  
 - THERE IS NO PROTECTION ZONE AS DEFINED IN ASCE 34-10.  
 - PROVIDE FULLY WELDED END CAPS AT EXPOSED OPEN ENDS OF  
 STEEL / ALUM. TUBES. MATCH THICKNESS LINE FOR LINE.  
 - SLOPE TOP OF EXPOSED FOOTING AWAY FROM DIRECT BURIAL POSTS  
 - ALL EXPOSED STEEL TO BE PRIMED & PAINTED OR ALTERNATIVELY  
 USE GALVANIZED STEEL.  
 ANCHORS:  
 - BRAND NAME APPROVED POST INSTALLED ANCHORS SPECIFIED ON  
 PLANS MAY BE SUBSTITUTED BY APPROVED EQUAL.

**STEEL:**  
 DESIGN AND FABRICATION ACCORDING TO 2008 IBC  
 - ROUNDED PIPE, ASTM A53 GRADE B OR EQUIVALENT  
 - HSS ROUND, SQUARE, AND RECTANGULAR TUBE: ASTM A500 GRADE B  
 OR EQUIVALENT  
 - ALL STEEL WELDED JOINTS SHOULD BE: ASTM F1554  
 - ALL ANCHORS BOLTS SHOULD BE: ASTM A307  
 - BEARING TYPE CONNECTION REINFORCING REBAR: ASTM A630  
 60 DEFORMED BARS  
 ALUMINUM:  
 DESIGN AND FABRICATION ACCORDING TO 2015 ALUM. DESIGN MANUAL  
 - PLATES ANGLES CHANNELS, TEE, AND SQUARE TUBING: ALUMINUM  
 ALLOY 6061 - T6 WITH 0.0981 IN PER CUBIC INCH.

**WELDING:**  
 DESIGN AND FABRICATION ACCORDING TO AWS D11.  
 - AWS CERTIFICATION REQUIRED FOR ALL STRUCTURAL WELDERS.  
 - EWS XX ELECTRODE FOR SHAWPROCESS  
 - EWS XX ELECTRODE FOR GRAMPROCESS  
 - ALL WELDS SHALL BE MADE WITH A FILLER METAL THAT CAN PRODUCE  
 WELDS THAT HAVE A MINIMUM CHARPY ANCHOR TIGHTNESS OF 20 FT-LB  
 AT ZERO OF AS DETERMINED BY THE APPROPRIATE AWS AS CLASSIFICATION  
 TEST METHOD OR WFS. CERTIFICATION

**CONCRETE:**  
 DESIGN AND CONSTRUCTION ACCORDING TO AC 308.11  
 - COMPRESSIVE STRENGTH AT 28 DAYS: F'c = 2500 PSI  
 - MINIMUM: 4000 PSI  
 - CEMENT TYPE II OR IV, W/C RATIO 0.45 BY WEIGHT FOR  
 PIER AND CAISSON  
 - FUNDING CONCRETE MUST BE PUMPED AGAINST  
 UNDISTURBED EARTH  
 - MAINTAIN MANUAL 3' CONCRETE COVER OVER ALL  
 EMBEDDED STEEL  
 LATERAL SOIL BEARING PER IBC CLASS 3 TABLE 1600.2 (110)  
 PSEFTI, MODIFIED PER SECTION 1606.3.4.

REV. NO.	REV. DATE	REVISION
1	02/03/20	SCALE AS SHOWN
2	---	---
3	---	---

PROJECT LOCATION: CITY OF CANON CITY  
 INTERSECTIONS OF S 1ST ST & STATE HWY 50, FREMONT DR. & N. HWY B  
 CANON CITY, CO





# SIGNAGE LOCATION PLAN GRID

The Signage Location Plan Grid is a programming tool that breaks up areas of Cañon City into sections to help identify signage locations. The following pages contain an individual grid section and identify sign locations within that area.

The highlighted areas indicate which quadrants of the sign location plan grid the signs will be located in.

Signs included on the following sign location plans are color coded to identify the intent of what type of sign is to be located in that position.



125 Hillside Drive Greenville, South Carolina 29607 Phone: 864-233-0401 National Toll Free: (800) 353-9132 www.hiltondisplays.com OIID / 19-48023

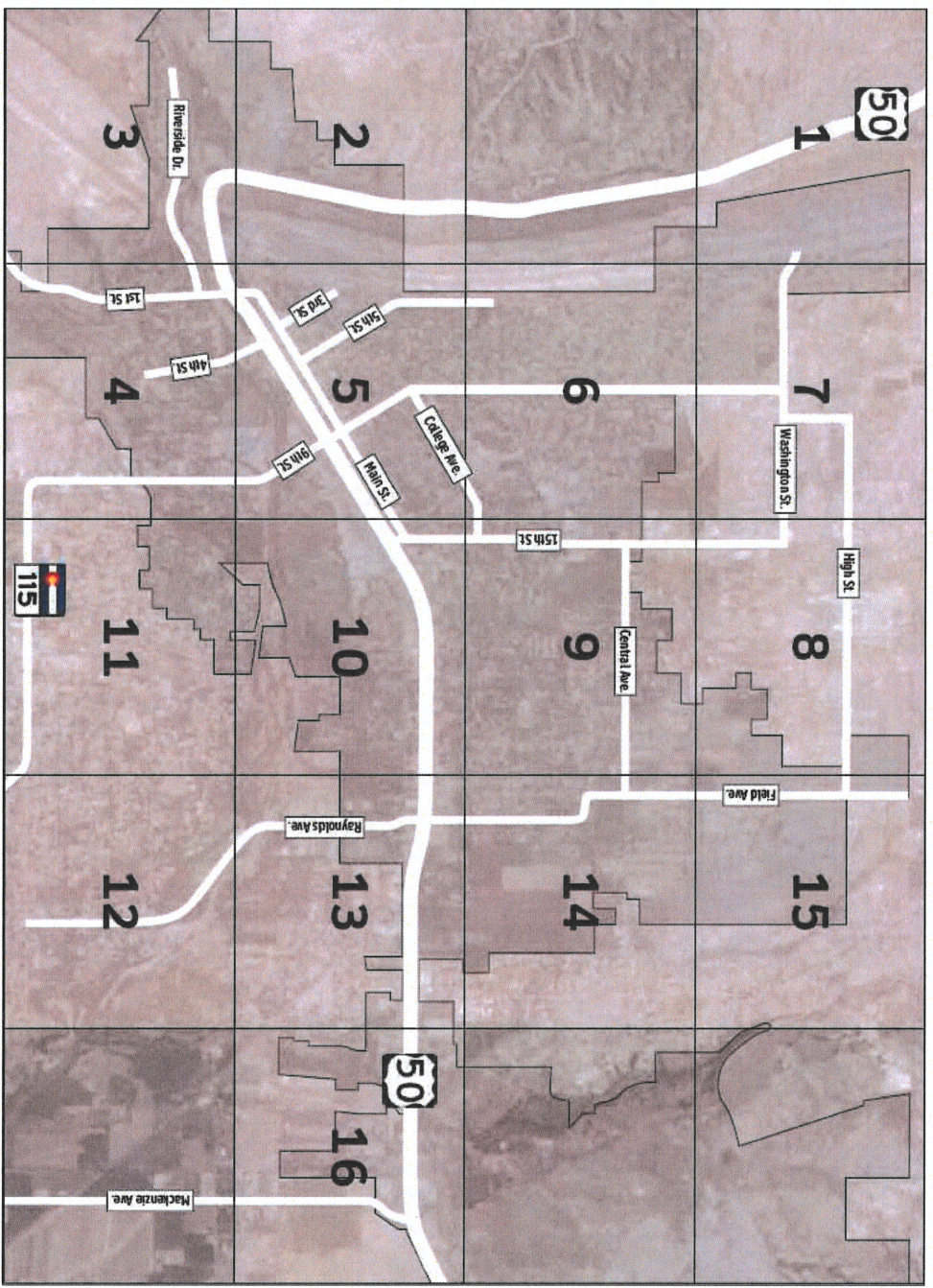

THIS MATERIAL IS THE ORIGINAL AND UNPUBLISHED WORK OF HILTON DISPLAYS AND MAY NOT BE REPRODUCED, COPIED, OR EXHIBITED IN ANY FASHION WITHOUT WRITTEN CONSENT FROM AN AUTHORIZED OFFICER OF THE COMPANY. © HILTON DISPLAYS 2020



**SIGNAGE LOCATION PLAN**

- A.3 GATEWAY MONUMENT
- B.1 FREESTANDING DOT VEHICULAR DIRECTIONAL
- B.2 FREESTANDING DOT VEHICULAR DIRECTIONAL
- C.1 DISTRICT IDENTIFICATION

**NOTE: FINAL SIGN LOCATIONS TO BE REVIEWED AND / OR ADJUSTED BY OWNER AS NEEDED**



\*COLOR REPRESENTS SIGN TYPE

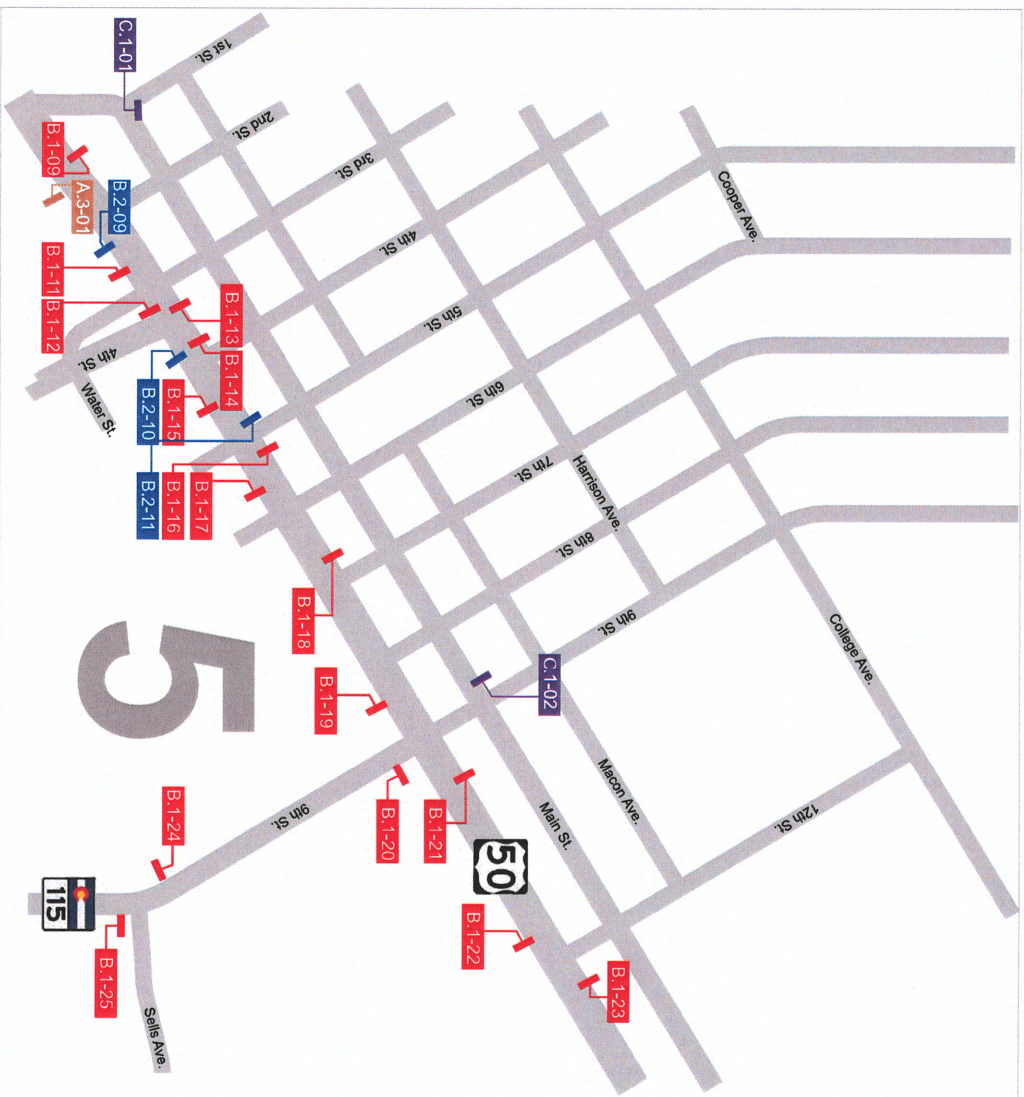
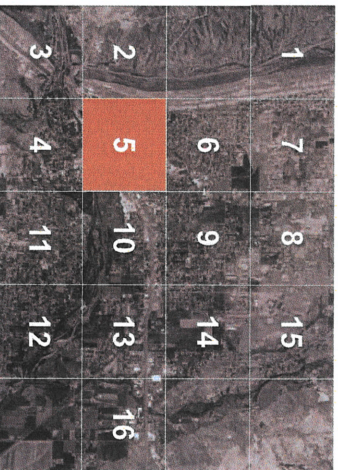



## SIGNAGE LOCATION PLAN

- A.3 GATEWAY MONUMENT
- B.1 FREESTANDING DOT VEHICULAR DIRECTIONAL
- B.2 FREESTANDING DOT VEHICULAR DIRECTIONAL
- C.1 DISTRICT IDENTIFICATION

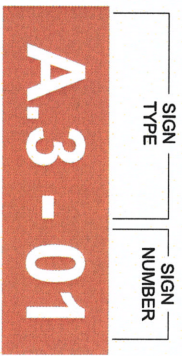

\*COLOR REPRESENTS SIGN TYPE

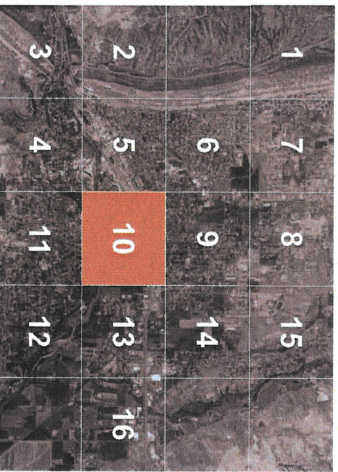



---

2019



CITY OF

**CAÑON CITY**

**Brand Book**

City of Cañon City  
Cañon City, CO  
QID# 19-48023

**SIGN TYPE B.1**  
**F/S DOT DIRECTIONAL**

**Designer:**  
Greg Sloan

**Date:**  
1-13-2020



125 Hillside Drive Greenville, South Carolina 29607

Phone: 864-233-0401

National Toll Free: (800) 363-9132

[www.hiltondisplays.com](http://www.hiltondisplays.com)



# Color Palette

PANTONE / VINYL / PAINT

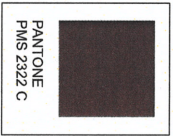

P-4 PAINT  
MP 2322 BROWN GOLD  
METALLIC (SATIN FINISH)

D-4 DIGITAL PRINT  
ON 3M 3830DS HIGH  
INTENSITY PRISMATIC  
REFLECTIVE SHEETING



D-4 DIGITAL PRINT  
ON 3M 3830DS HIGH  
INTENSITY PRISMATIC  
REFLECTIVE SHEETING



P-4 PAINT  
MP 877 B SUNSET  
SILVER METALLIC  
(SATIN FINISH)

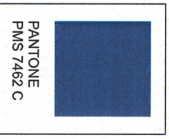

D-5 DIGITAL PRINT  
ON 3M 3830DS HIGH  
INTENSITY PRISMATIC  
REFLECTIVE SHEETING



P-4 PAINT  
MP 7690 TONYA BLUE  
(SATIN FINISH)

D-4 DIGITAL PRINT  
ON 3M 3830DS HIGH  
INTENSITY PRISMATIC  
REFLECTIVE SHEETING

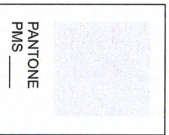

V-2 VINYL GRAPHICS  
3M 3835-70 / 80%  
DIFFUSER FILM

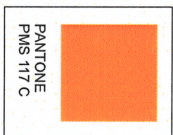

D-4 DIGITAL PRINT  
ON 3M 3830DS HIGH  
INTENSITY PRISMATIC  
REFLECTIVE SHEETING

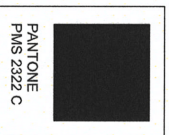

P-4 PAINT  
MP 33853 BLACK  
STALLION (SATIN FINISH)



**NOTE:**  
Color and Typography specifications shown are for all signage and graphics contained within the overall site design package. Not all colors and/or fonts are used for each individual sign type included herein.

## Graphic Elements

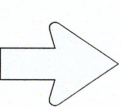

STRAIGHT



LEFT



RIGHT



STRAIGHT AND TO THE LEFT



STRAIGHT AND TO THE RIGHT

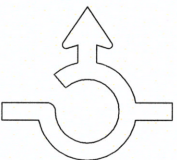

ROUNDABOUT LEFT

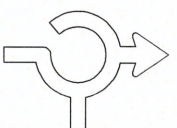

ROUNDABOUT STRAIGHT

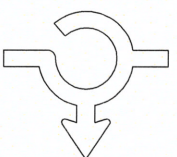

ROUNDABOUT RIGHT

## Typography

P2 OF 18

CLEARVIEW HIGHWAY 5-W-R / Normal

ABCDEFGHIJKLMNOPQRSTUVWXYZ  
abcdefghijklmnopqrstuvwxyz  
1234567890&?

SENTINEL / Bold

ABCDEFGHIJKLMNOPQRSTUVWXYZ  
abcdefghijklmnopqrstuvwxyz  
0123456789 Ñ ñ

## Symbols



**HILTON DISPLAYS**  
125 HILLSIDE DRIVE • GREENVILLE SC 29607  
P 803 353 9132 • F 864 242 2304  
www.hiltondisplays.com

**QID 19-48023**

JOB NAME  
City of Canon City  
LOCATION  
Canon City, CO  
CUSTOMER CONTACT

SALESMAN / PM  
Mike Melhem  
DESIGNER  
Greg Sloan  
DWG. DATE  
1-06-2020  
REV. DATE / REVISION  
1-13-2020

SCALE  
FILE  
2019/City of Canon City/  
Canon City/  
19-48023/

DESIGN SPECIFICATIONS ACCEPTED BY:  
EST. CLIENT:  
SUSPENSE LANDLORD:  
THE AGENT OF THIS DRAWING IS TO SHOW A CONCEPTUAL REPRESENTATION OF THE PROPOSED SIGNAGE. DUE TO VARIATIONS IN PRINTING DEVICES AND SUBSTRATES, THE FINISHED PRODUCT MAY DIFFER SLIGHTLY FROM DRAWINGS.  
Underwriters Laboratories Inc.



## SIGN TYPE B.1 | DESIGNATION F/S DOT DIRECTIONAL | B.1-01 - B.1-35

QTY: 33

- DIGITAL PRINT**
- D1: PMS 2322 C Brown
  - D2: PMS 117 C Gold
  - D3: PMS 2807 C Purple
  - D4: PMS 7890 C Blue
  - D5: PMS 7642 C Blue

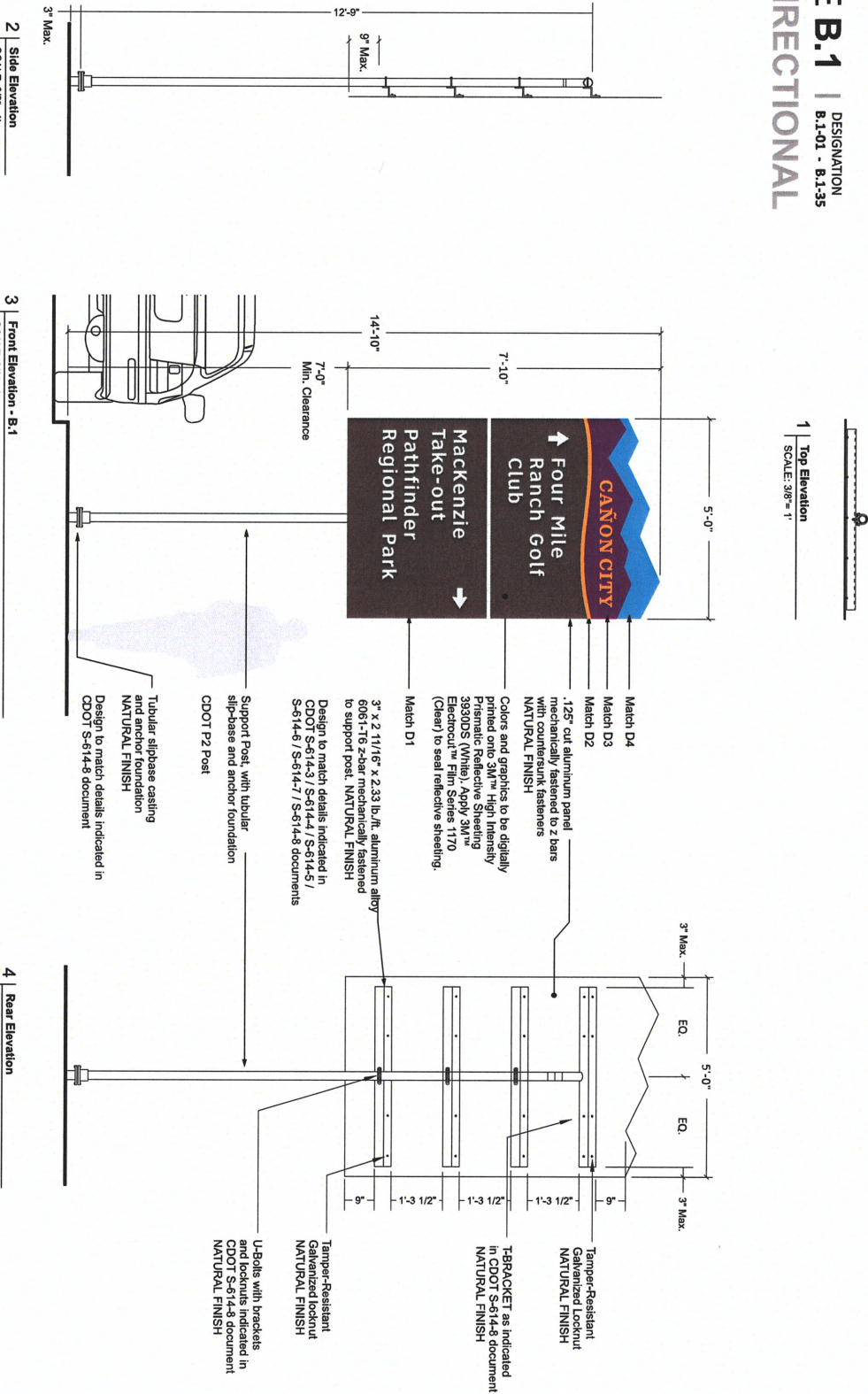

THIS DESIGN IS THE ORIGINAL AND UNPUBLISHED WORK OF HILTON DISPLAYS AND MAY NOT BE REPRODUCED, COPIED, OR EXHIBITED IN ANY MANNER WITHOUT WRITTEN CONSENT FROM AN AUTHORIZED OFFICER OF THE COMPANY. © HILTON DISPLAYS 2019



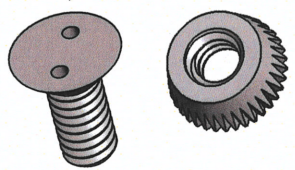
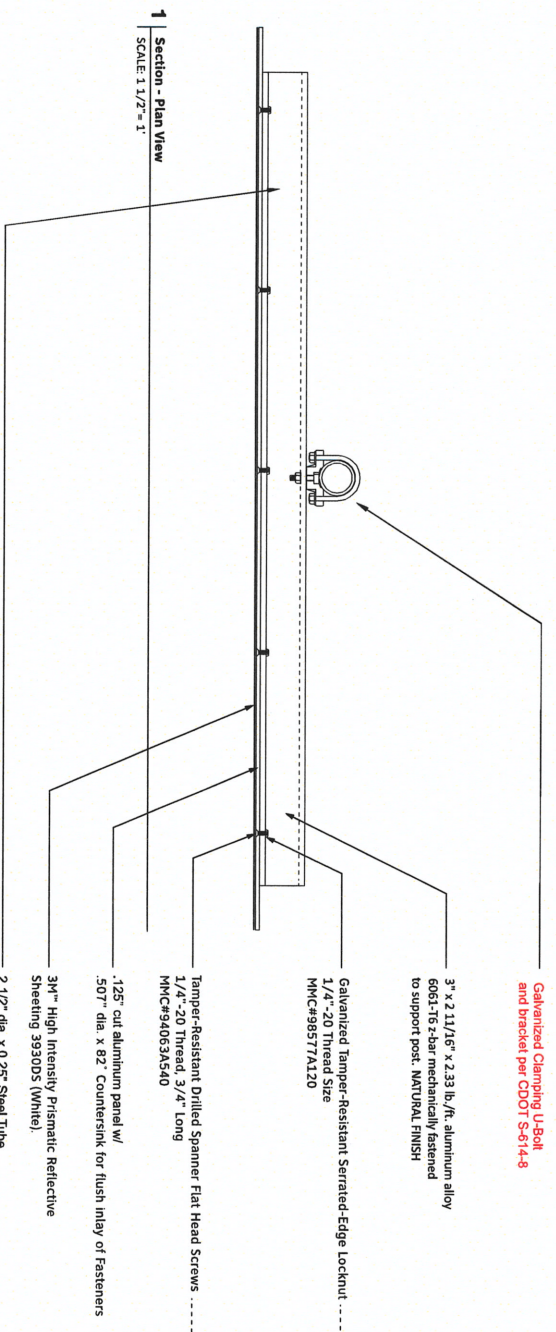

**NOTE \***  
Fasteners to be installed countersunk on Sign Panel prior to application of vinyl sheeting on face. Fasteners should NOT be visible on finished Sign Face

**NOTE**  
Design to match details indicated in CDOT S-614-4 and S-614-8 documents

THIS DESIGN IS THE ORIGINAL AND UNPUBLISHED WORK OF HILTON DISPLAYS AND MAY NOT BE REPRODUCED, COPIED, OR EXHIBITED IN ANY MANNER WITHOUT WRITTEN CONSENT FROM AN AUTHORIZED OFFICER OF THE COMPANY. © HILTON DISPLAYS 2019



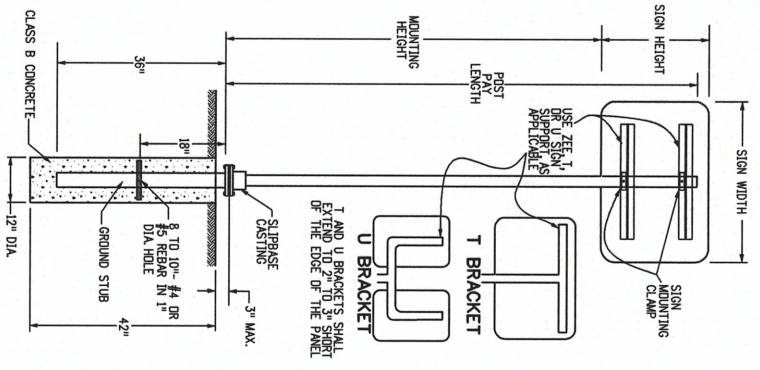

**TUBULAR STEEL POST (WITH SLIPBASE) (FOR USE WITH ALL P1 AND P2 POST INSTALLATIONS) (SEE SHEET 1 FOR P-POST INSTALLATIONS)**

**GENERAL NOTE**  
THE CONTRACTOR SHALL INSTALL THE POSTS PER THE MANUFACTURER'S RECOMMENDATIONS WITHOUT ADDITIONAL COMPENSATION.

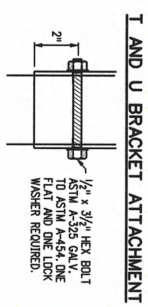

**TYPICAL SINGLE BRACKET**

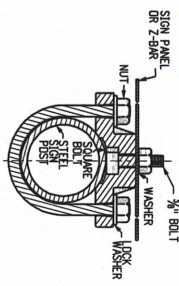

**TYPICAL BACK TO BACK**

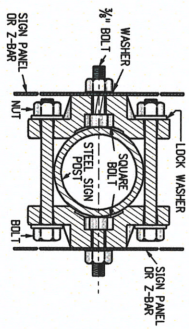

**DETAILS FOR SIGN PANEL ATTACHMENT**

**DIMENSIONS FOR MOUNTING CLAMP (ALL DIMENSION ARE IN INCHES)**

STANDARD PIPE SIZE	A	B	C	D	E	F	G	K	L	R <sub>1</sub>	R <sub>2</sub>
2	3 3/4	2 1/2	1 1/2	1 1/2	1/2	3/8	1	2 1/2	1 1/2	1 1/2	1 1/2
2 1/2	4 1/4	3 1/4	2	1 1/2	1/2	1/2	1	3 3/4	1 1/2	1 1/2	1 1/2

**PIPE CLAMP CASTING**  
PIPE CLAMP CASTING SHALL BE ASTM B36 OR B36B ALUMINUM ALLOY A444-07-14 OR 356-0-F. ALL SIGN MOUNTING CLAMP PARTS NOT MADE FROM ALUMINUM SHALL BE GALVANIZED STEEL IN CONFORMANCE WITH ASTM A503 OR STAINLESS STEEL.

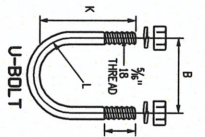

U-BOLT TO BE MADE IN ACCORDANCE WITH STANDARD MANUFACTURING PROCEDURE 1/4" OR 5/8" DIAMETER STOCK IS PERMISSIBLE. AMERICAN STANDARD REGULAR HEX NUTS AND SPRING LOCKWASHERS.

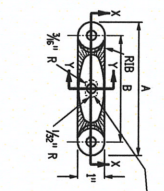

SLOT TO HOLD HEAD OF 3/8" HEX HEAD BOLT. THE BOLT SHALL BE 1/2" LONG, WITH FULL THREADS, A MEDIUM WREDS, AN ALUMINUM STEEL OR ALUMINUM SELF-LOCKING HEX HEAD NUT. THE BOLT HEAD MUST NOT TURN IN THE SLOT.

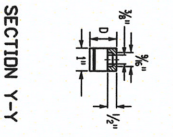
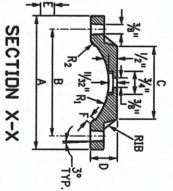

**MOUNTING CLAMP FOR SOCKET OR SLIPBASE**

THIS DESIGN IS THE ORIGINAL AND UNPUBLISHED WORK OF HILTON DISPLAYS AND MAY NOT BE REPRODUCED, COPIED, OR EXHIBITED IN ANY MANNER WITHOUT WRITTEN CONSENT FROM AN AUTHORIZED OFFICER OF THE COMPANY. © HILTON DISPLAYS 2019



**STEEL SIGN SUPPORT SLIPBASE INSTALLATION**

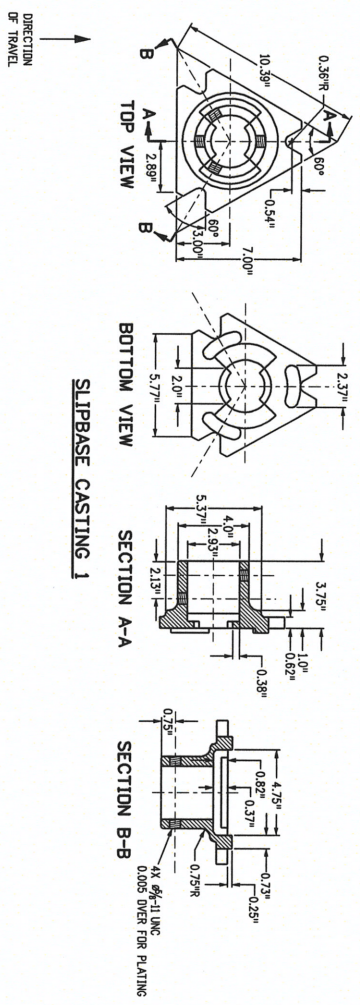

**SLIPBASE CASTING 1**

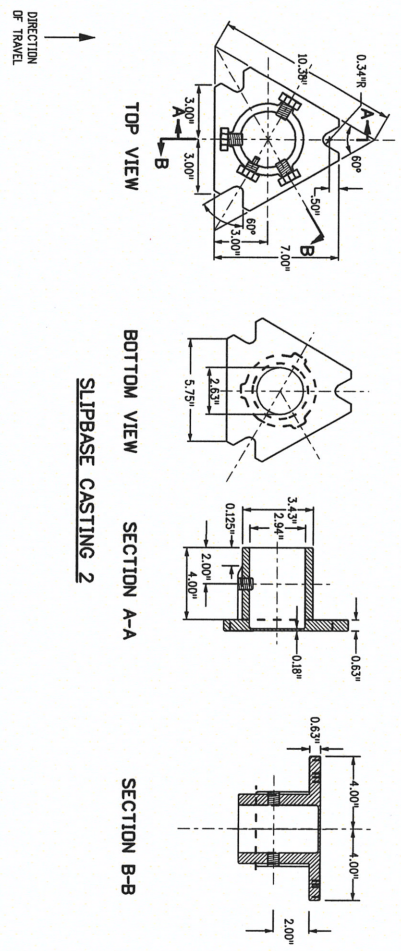

**SLIPBASE CASTING 2**

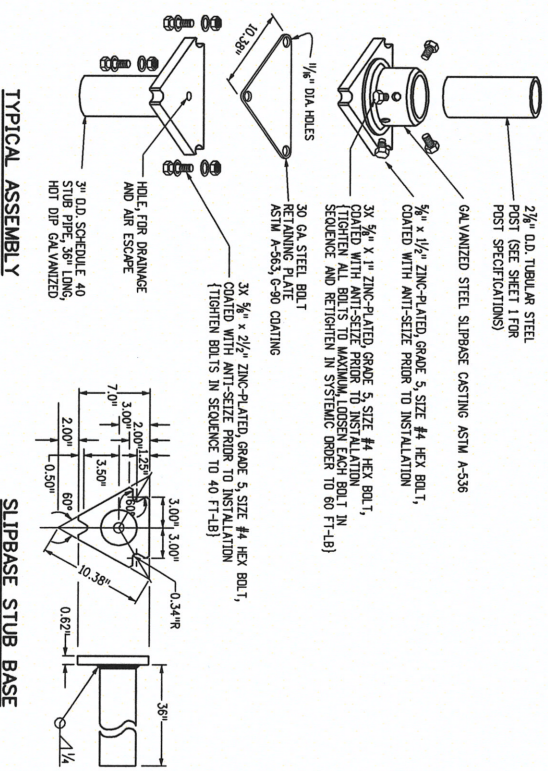

**TYPICAL ASSEMBLY**

**SLIPBASE STUB BASE**

**SLIPBASE CASTING REQUIREMENTS**

- FOR 2-7/8 INCH POSTS (P1 OR P2 POSTS)
- GALVANIZED STEEL SLIPBASE CASTING ASTM A-536
- 1 - EACH 3/4" x 1/2" INCH LONG ZINC-PLATED, GRADE 5
- 3 - EACH 3/4" x 1/2" INCH LONG ZINC-PLATED, GRADE 5
- 1 - EACH 3/4" x 1/2" INCH LONG ZINC-PLATED, GRADE 5
- 1 - EACH 30 GAUGE STEEL BOLT RETAINING PLATE ASTM A-593, G-90 COATING

**INSTALLATION REQUIREMENTS**

- ALL HEX BOLTS SHALL BE COATED WITH ANTI-SEIZE PRIOR TO INSTALLATION



**TUBULAR STEEL SIGN SUPPORT SLIPBASE NOTES**

- REFER TO SIGNING PLANS FOR SIGN LOCATIONS AND HEIGHT
- MAXIMUM ALLOWABLE MOMENT FOR SIGN BASE SHALL BE 3000 LBS.
- MAXIMUM ALLOWABLE MOMENT FOR SIGN BASE SHALL BE 3000 LBS.
- PAY ITEM "STEEL SIGN SUPPORT (X-INCH ROUND) (SLIPBASE)" SHALL INCLUDE STUB BASE CASTING AND NECESSARY HARDWARE (SLIPBASE CASTING MOUNTING HARDWARE AS SHOWN ON STD S-614-B-SHEET 3)
- PAY ITEM "STEEL SIGN SUPPORT CASTING" SHALL INCLUDE CASTING AND NECESSARY MOUNTING HARDWARE (SLIPBASE CASTING MOUNTING HARDWARE AS SHOWN ON STD S-614-B-SHEET 3)
- PAY ITEM "STEEL SIGN GROUND STUB BASE (36") SHALL INCLUDE SLIPBASE STUB BASE

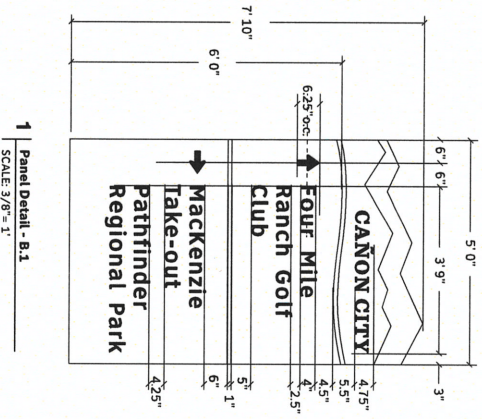

**SIGN TYPE B.1 | DESIGNATION  
B.1-01 - B.1-35**  
**F/S DOT DIRECTIONAL**  
COPY LAYOUT SPECIFICATIONS AND LOCATION VARIATIONS

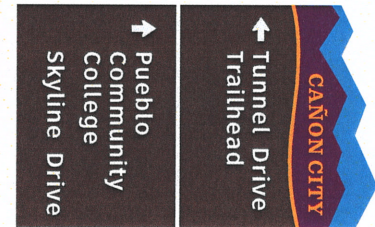

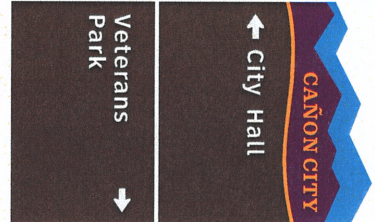
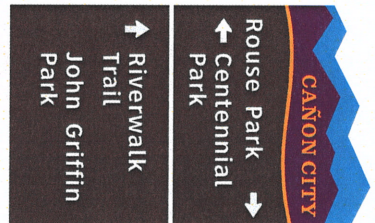
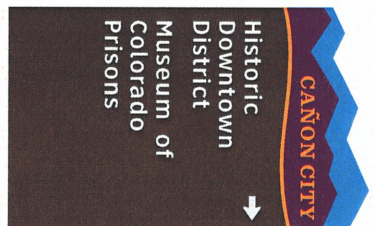
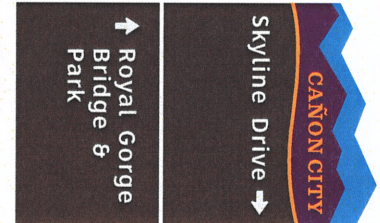
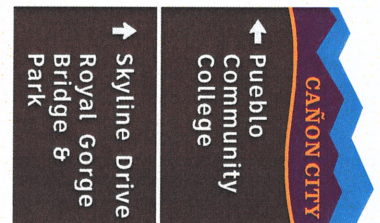
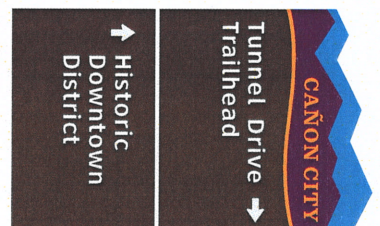
- |        |   |        |   |        |   |        |  |        |   |
|--------|---|--------|---|--------|---|--------|--|--------|---|
| B.1-05 |  <p>CAÑON CITY<br/>Tunnel Drive Trailhead<br/>Pueblo Community College<br/>Skyline Drive</p> | B.1-06 |  <p>CAÑON CITY<br/>Historic Downtown District<br/>Museum of Colorado Prisons<br/>River District</p> | B.1-07 |  <p>CAÑON CITY<br/>City Hall<br/>Veterans Park</p>   | B.1-08 |  <p>CAÑON CITY<br/>Rouse Park<br/>Centennial Park<br/>Riverwalk Trail<br/>John Griffin Park</p> | B.1-09 |  <p>CAÑON CITY<br/>Historic Downtown District<br/>Museum of Colorado Prisons</p> |
| B.1-01 |  <p>CAÑON CITY<br/>Skyline Drive<br/>Royal Gorge Bridge &amp; Park</p>                     | B.1-02 |  <p>CAÑON CITY<br/>Pueblo Community College<br/>Tunnel Drive Trailhead</p>                        | B.1-03 |  <p>CAÑON CITY<br/>Pueblo Community College<br/>Skyline Drive<br/>Royal Gorge Bridge &amp; Park</p> | B.1-04 |  <p>CAÑON CITY<br/>Tunnel Drive<br/>Historic Downtown District</p>                             |        |   |





125 Hillside Drive Greenville, South Carolina 29607

Phone: 864-233-0401

National Toll Free: (800) 353-9132

www.hiltondisplays.com

OID / 19-48023



P8 OF 18

2019

**CAÑON CITY**

River District →  
Royal Gorge  
Rt. Railroad  
Riverwalk

B.1-11

**CAÑON CITY**

Centennial →  
Park  
← Macon Plaza  
Fremont Ctr.  
for the Arts

B.1-12

**CAÑON CITY**

← River District  
Royal Gorge  
Rt. Railroad  
Riverwalk  
Trail

B.1-13

**CAÑON CITY**

← Centennial  
Park  
← River District  
Royal Gorge  
Rt. Railroad

B.1-14

**CAÑON CITY**

← Macon Plaza  
Library  
Fremont  
Center for  
the Arts  
HISTORIC DOWNTOWN

B.1-15

**CAÑON CITY**

Macon Plaza →  
Library  
Fremont  
Center for  
the Arts  
HISTORIC DOWNTOWN

B.1-16

**CAÑON CITY**

Royal Gorge →  
Museum &  
History Ctr.  
← Fremont  
County  
Admin. Bldg.

B.1-17

**CAÑON CITY**

← Royal Gorge  
Museum &  
History Ctr.  
Fremont  
County  
Admin. Bldg. →

B.1-18

**CAÑON CITY**

← Historic  
Downtown  
District  
← Cañon City  
Middle  
School  
Rudd Park

B.1-19

**CAÑON CITY**

← Historic  
Downtown  
District  
← Royal Gorge  
Museum &  
History Ctr.

B.1-20

**CAÑON CITY**

Historic  
Downtown  
District →  
← Royal Gorge  
Museum &  
History Ctr.

B.1-21

**CAÑON CITY**

← Cañon City  
Middle  
School  
Rudd Park  
← Post Office

B.1-22



**CAÑON CITY**

Cañon City →  
Middle School  
Rudd Park

B.1-23

**CAÑON CITY**

← Riverwalk  
Trail  
John Griffin Park

↑ Rouse Park

B.1-24

**CAÑON CITY**

Riverwalk →  
Trail  
John Griffin Park

↑ Historic Downtown District

B.1-25

**CAÑON CITY**

Post Office →  
H Hospital

↑ Historic Downtown District

B.1-26

**CAÑON CITY**

Riverwalk →  
Trail

← Garden Park  
Fossil Area  
Oil Well Flats

B.1-27

**CAÑON CITY**

← Riverwalk  
Trail

↑ Historic Downtown District

B.1-28

**CAÑON CITY**

← Abbey

↑ Justice Ctr. Complex  
Four Mile Ranch Golf Club

B.1-29

**CAÑON CITY**

Justice Ctr. →  
Complex

↑ Four Mile Ranch Golf Club  
Mackenzie Take-out

B.1-31

**CAÑON CITY**

← Justice Ctr. Complex

↑ Abbey  
Historic Downtown District

B.1-32

**CAÑON CITY**

↑ Four Mile Ranch Golf Club

→ Mackenzie Take-out  
Pathfinder Regional Park

B.1-33

**CAÑON CITY**

↑ Historic Downtown District

← Mackenzie Take-out  
Pathfinder Regional Park

B.1-34

**CAÑON CITY**

Riverwalk  
Trail

John Griffin Park  
Historic Downtown District

B.1-35





# SIGNAGE LOCATION PLAN GRID

The Signage Location Plan Grid is a programming tool that breaks up areas of Cañon City into sections to help identify signage locations. The following pages contain an individual grid section and identify sign locations within that area.

The highlighted areas indicate which quadrants of the sign location plan grid the signs will be located in.

Signs included on the following sign location plans are color coded to identify the intent of what type of sign is to be located in that position.



125 Hillside Drive Greenville, South Carolina 29607

Phone: 864-233-0401

National Toll Free: (800) 353-9132

www.hiltondisplays.com

OIDD / 19-48023

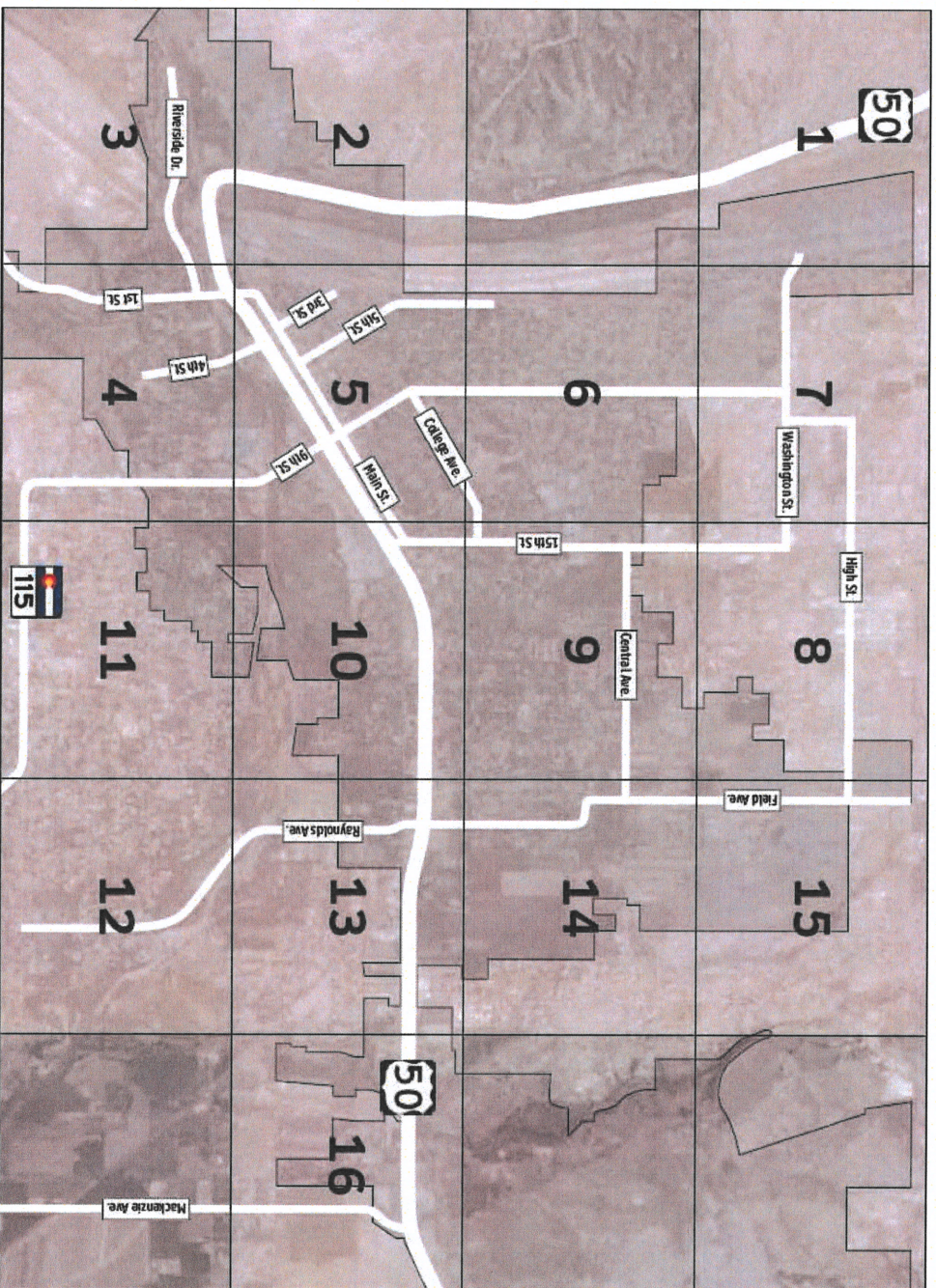



**SIGNAGE LOCATION PLAN**

- A.3 GATEWAY MONUMENT
- B.1 FREESTANDING DOT VEHICULAR DIRECTIONAL
- B.2 FREESTANDING DOT VEHICULAR DIRECTIONAL
- C.1 DISTRICT IDENTIFICATION



\*COLOR REPRESENTS SIGN TYPE

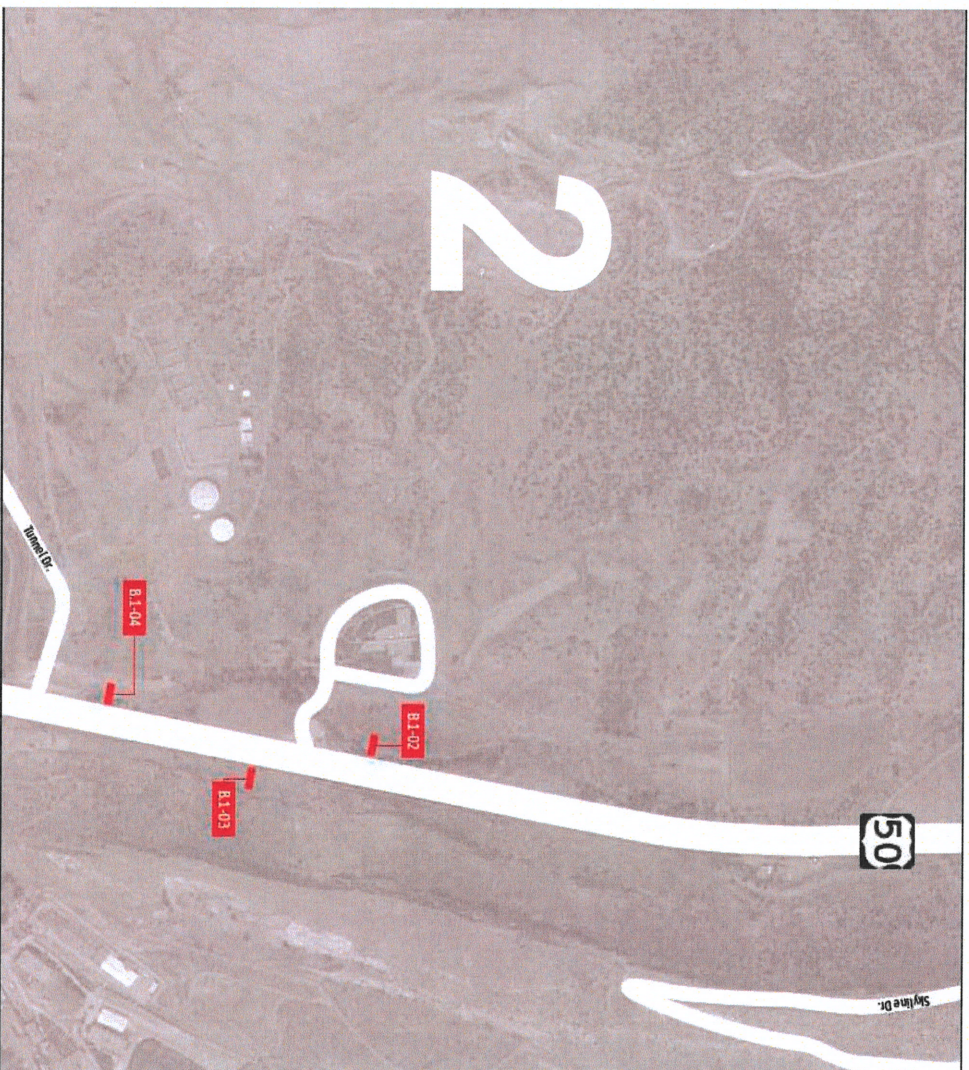



## SIGNAGE LOCATION PLAN

- A.3 GATEWAY MONUMENT
- B.1 FREESTANDING DOT VEHICULAR DIRECTIONAL
- B.2 FREESTANDING DOT VEHICULAR DIRECTIONAL
- C.1 DISTRICT IDENTIFICATION



\*COLOR REPRESENTS SIGN TYPE

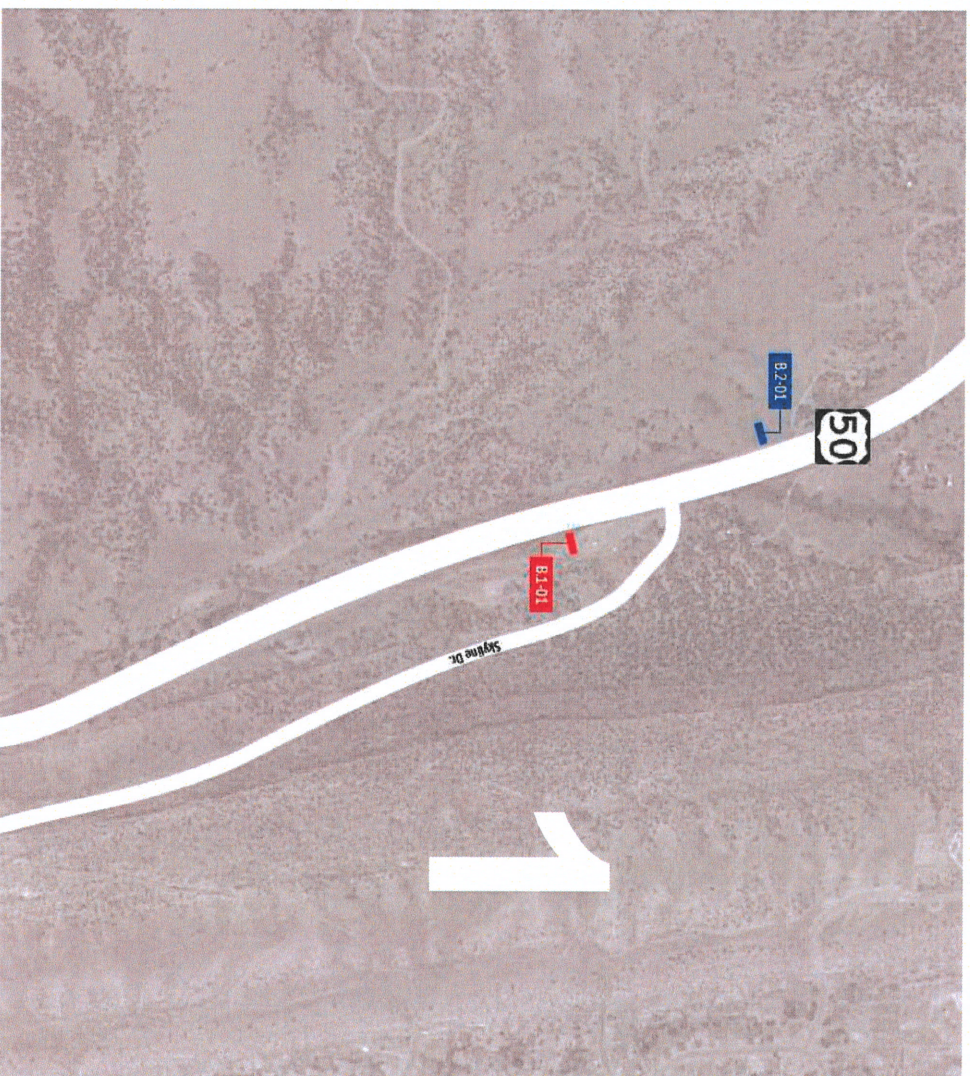
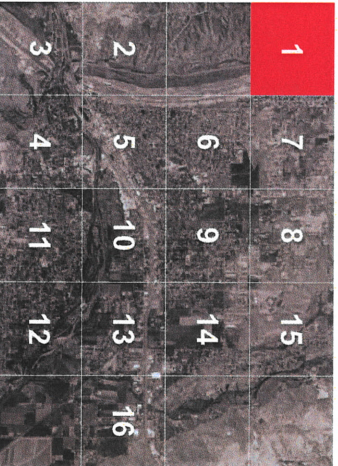



## SIGNAGE LOCATION PLAN

- A.3 GATEWAY MONUMENT
- B.1 FREESTANDING DOT VEHICULAR DIRECTIONAL
- B.2 FREESTANDING DOT VEHICULAR DIRECTIONAL
- C.1 DISTRICT IDENTIFICATION



\*COLOR REPRESENTS SIGN TYPE

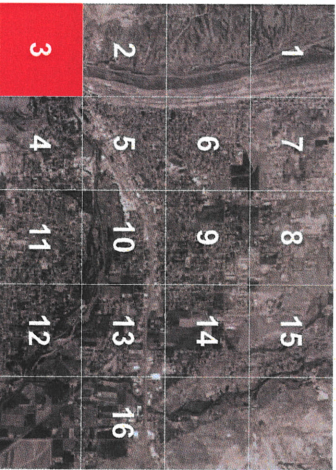



## SIGNAGE LOCATION PLAN

- A.3 GATEWAY MONUMENT
- B.1 FREESTANDING DOT VEHICULAR DIRECTIONAL
- B.2 FREESTANDING DOT VEHICULAR DIRECTIONAL
- C.1 DISTRICT IDENTIFICATION



\*COLOR REPRESENTS SIGN TYPE

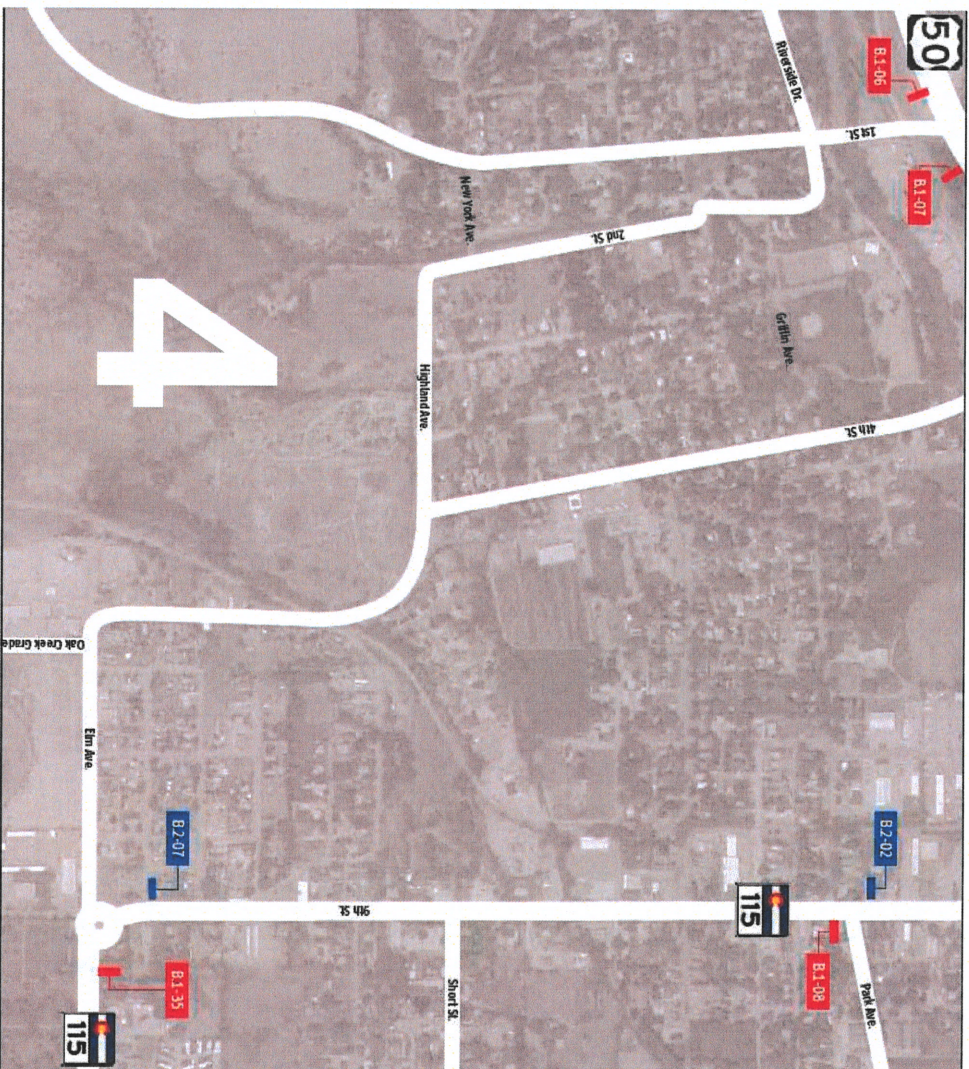





CITY OF  
**CAÑON CITY**

125 Hillside Drive Greenville, South Carolina 29607 Phone: 864-233-0401 National Toll Free: (800) 353-9132 www.hiltondisplays.com



P15 OF 18

2019

OID / 19-48023

## SIGNAGE LOCATION PLAN

- A.3 GATEWAY MONUMENT
- B.1 FREESTANDING DOT VEHICULAR DIRECTIONAL
- B.2 FREESTANDING DOT VEHICULAR DIRECTIONAL
- C.1 DISTRICT IDENTIFICATION

**NOTE: FINAL SIGN LOCATIONS TO BE REVIEWED AND / OR ADJUSTED BY OWNER AS NEEDED**



\*COLOR REPRESENTS SIGN TYPE

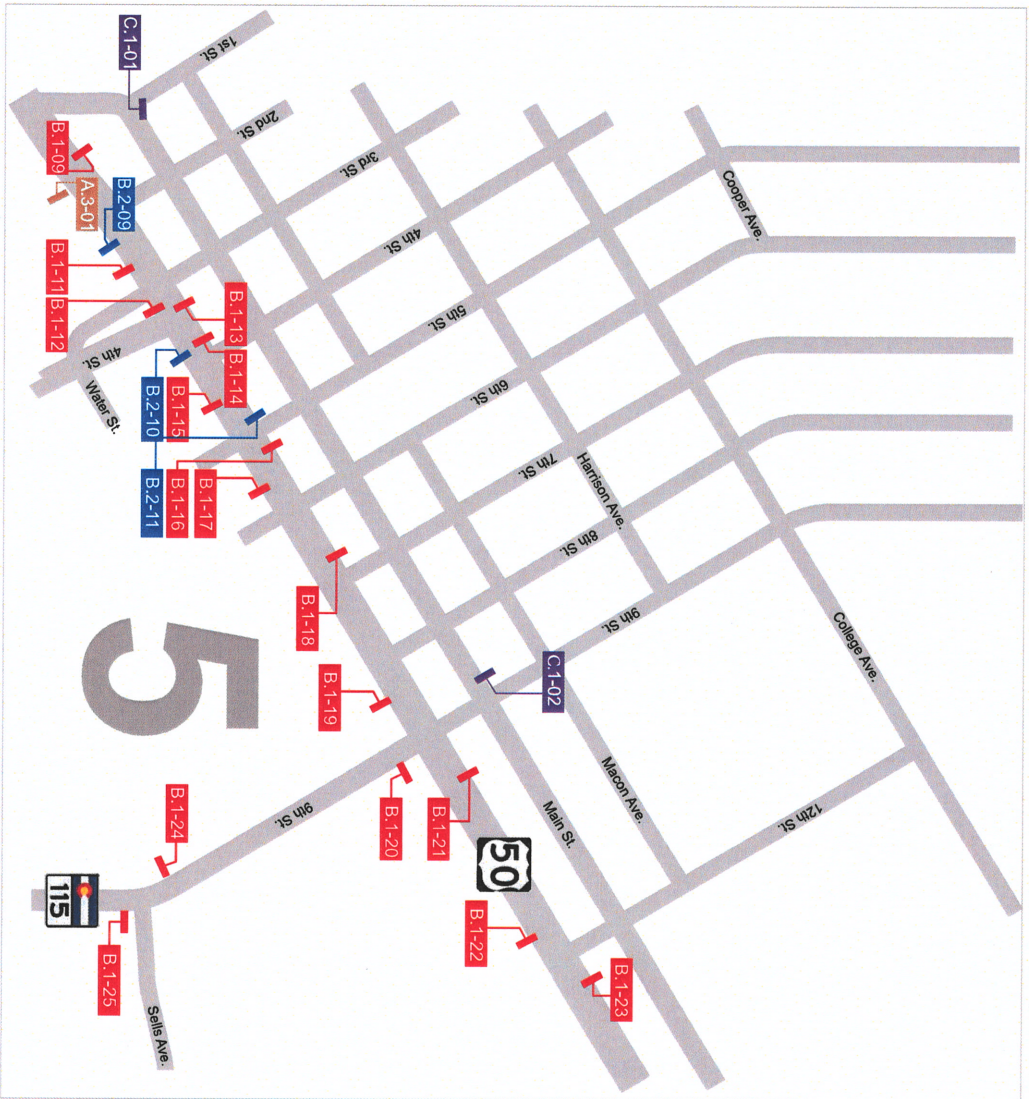





125 Hillside Drive Greenville, South Carolina 29607

Phone: 864-233-0401

National Toll Free: (800) 353-9132

www.hiltondisplays.com

OID / 19-48023



P16 OF 18

2019

# SIGNAGE LOCATION PLAN

- A.3 GATEWAY MONUMENT
- B.1 FREESTANDING DOT VEHICULAR DIRECTIONAL
- B.2 FREESTANDING DOT VEHICULAR DIRECTIONAL
- C.1 DISTRICT IDENTIFICATION



**B.1 - 01**

\*COLOR REPRESENTS SIGN TYPE







125 Hillside Drive Greenville, South Carolina 29607

Phone: 864-233-0401

National Toll Free: (800) 353-9132

www.hiltondisplays.com

OID / 19-48023



P17 OF 18

2019

# SIGNAGE LOCATION PLAN

- A.3 GATEWAY MONUMENT
- B.1 FREESTANDING DOT VEHICULAR DIRECTIONAL
- B.2 FREESTANDING DOT VEHICULAR DIRECTIONAL
- C.1 DISTRICT IDENTIFICATION



COLOR REPRESENTS SIGN TYPE

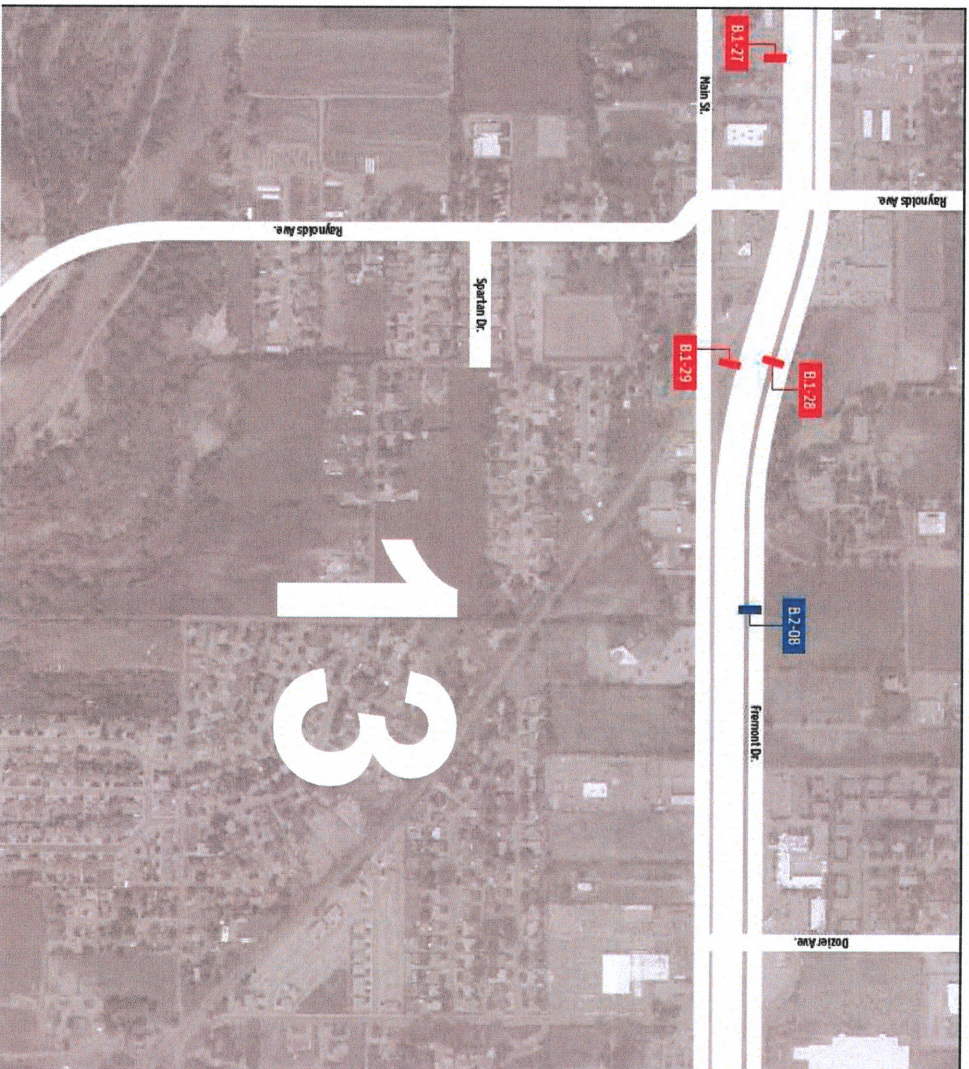
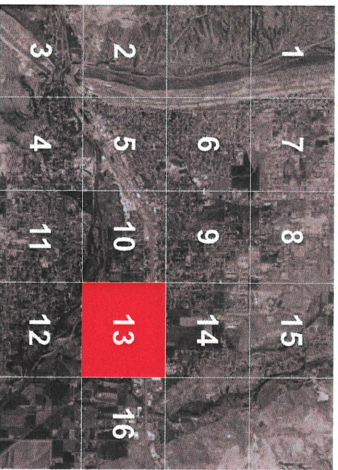



## SIGNAGE LOCATION PLAN

- A.3 GATEWAY MONUMENT
- B.1 FREESTANDING DOT VEHICULAR DIRECTIONAL
- B.2 FREESTANDING DOT VEHICULAR DIRECTIONAL
- C.1 DISTRICT IDENTIFICATION



\*COLOR REPRESENTS SIGN TYPE

